



**WACKER
NEUSON**
all it takes!

Hubkrafttabellen ET20



Abb. 1: Hubkrafttabelle
Oberwagen nicht gekippt



Abb. 2: Hubkrafttabelle – Oberwagen gekippt,
Armsystem bergauf (Hangneigung 15°)



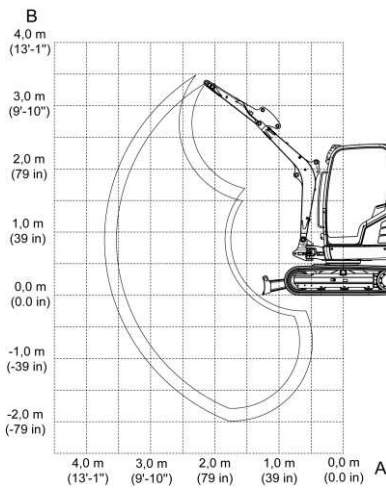



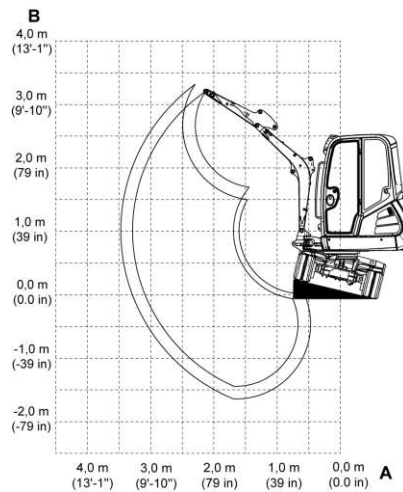

Abb. 3: Hubkrafttabelle – Oberwagen gekippt,
Armsystem bergauf (Hangneigung 15°)

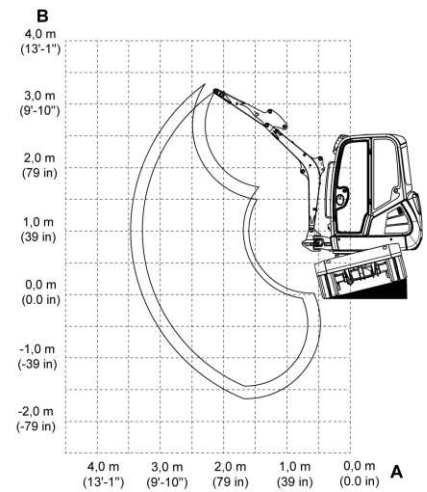
Bezeichnung	Erklärung
A	Ausladung von Drehkranzmitte
B	Lasthakenhöhe
max	Zulässige Gewichts- oder Massewert bei gestrecktem Armsystem
	Mit oder ohne Planierschildabstützung in Fahrtrichtung
	Mit oder ohne Planierschildabstützung 90° zur Fahrtrichtung
	Planierschild unten
	Planierschild oben
	Telefahrwerk ausgefahren

Die Hubkraft des Fahrzeugs ist durch die hydraulische Leistung bzw. durch die Kippsicherheit begrenzt.

Es werden weder 75% der statischen Kipplast noch 87% der hydraulischen Hubkraft überschritten.

Berechnungsgrundlage: gemäß ISO 10567. Einstelldruck am Hubarmzylinder:

ET 20: 20000 kPa (2900 psi)





















Die Hubfähigkeit gilt für Fahrzeuge unter folgenden Bedingungen:

- Schmier- und Betriebsmittel auf den vorgeschriebenen Ständen.
- Voller Kraftstofftank.
- Kabine oder Canopy.
- Fahrzeug auf Betriebstemperatur.
- Gewicht des Fahrers 75 kg (165 lbs).



















**WACKER
NEUSON**
all it takes!

Hubkrafttabellen ET20 – Oberwagen nicht gekippt

A B				3,0 m (9'-10")			2,5 m (98 in)			2,0 m (79 in)			1,5 m (59 in)			3,0 m (9'-10")			2,5 m (98 in)		
																					
2,5 m (98 in)	382 (842)	355 (783)	322 (710)	-	-	-	-	385 (849)	349 (770)	316 (697)	355 (783)	355 (783)	355 (783)	-	-	-	-	-	-	-	-
2,0 m (79 in)	383 (845)	304 (670)	275 (606)	-	-	-	-	378 (834)	348 (767)	316 (697)	384 (847)	384 (847)	384 (847)	-	-	-	-	-	-	-	-
1,0 m (39 in)	397 (875)	263 (580)	237 (523)	399 (880)	266 (586)	240 (529)	445 (981)	333 (734)	301 (664)	532 (1,173)	432 (953)	389 (858)	722 (1,592)	593 (1,308)	531 (1,171)	-	-	-	-	-	-
0,0 m (0.0 in)	420 (926)	267 (589)	241 (531)	-	-	-	501 (1,105)	319 (703)	287 (633)	639 (1,409)	408 (900)	366 (807)	887 (1,956)	557 (1,228)	496 (1,094)	-	-	-	-	-	-
-1,0 m (-39 in)	443 (977)	332 (732)	299 (659)	-	-	-	-	-	-	578 (1,275)	407 (897)	364 (80)	778 (1,715)	558 (1,231)	497 (1,097)	-	-	-	-	-	-
-1,5 m (-59 in)	442 (975)	435 (959)	391 (862)	-	-	-	-	-	-	-	-	-	608 (1,341)	569 (1,255)	508 (1,120)	-	-	-	-	-	-

Tab.1: Hubkrafttabellen ET20 Oberwagen nicht gekippt, - Kabine und Telefahrwerk mit kurzem Löffelstiel

















A B				3,5 m (11'-6")			3,0 m (9'-10")			2,5 m (98 in)			2,0 m (79 in)		
															
2,5 m (98 in)	341 (752)	313 (690)	283 (624)	-	-	-	326 (719)	326 (719)	317 (699)	-	-	-	-	-	-
2,0 m (79 in)	345 (761)	272 (600)	246 (542)	-	-	-	334 (737)	334 (736)	314 (692)	330 (728)	330 (728)	330 (728)	-	-	-
1,0 m (39 in)	360 (794)	238 (525)	214 (472)	370 (816)	260 (573)	234 (516)	411 (906)	328 (723)	296 (653)	485 (1,069)	429 (946)	386 (851)	639 (1,409)	595 (1,312)	533 (1,175)
0,0 m (0.0 in)	382 (842)	240 (529)	215 (474)	400 (882)	251 (554)	225 (496)	484 (1,067)	311 (686)	279 (615)	616 (1,358)	400 (882)	358 (789)	863 (1,903)	548 (1,208)	487 (1,074)
-1,0 m (-39 in)	407 (897)	289 (637)	260 (573)	-	-	-	451 (995)	308 (679)	276 (609)	596 (1,314)	394 (869)	352 (776)	808 (1,782)	543 (1,197)	482 (1,063)
-1,5 m (-59 in)	416 (917)	360 (794)	323 (712)	-	-	-	-	-	-	492 (1,085)	401 (884)	359 (792)	679 (1,497)	552 (1,217)	491 (1,083)

Tab.2: Hubkrafttabellen ET20 Oberwagen gekippt, – Kabine und Telefahrwerk mit langem Löffelstiel



















**WACKER
NEUSON**
all it takes!

Hubkrafttabellen ET20 – Oberwagen nicht gekippt

A B				3,0 m (9'-10")			2,5 m (98 in)			2,0 m (79 in)			1,5 m (59m)		
															
2,5 m (98 in)	380 (838)	351 (774)	274 (604)	-	-	-	378 (834)	358 (789)	280 (617)	356 (785)	356 (785)	356 (785)	-	-	-
2,0 m (79 in)	383 (845)	305 (673)	235 (518)	-	-	-	380 (838)	356 (785)	278 (613)	394 (869)	394 (869)	374 (825)	-	-	-
1,0 m (39 in)	399 (880)	269 (593)	204 (450)	401 (884)	272 (600)	207 (456)	452 (997)	341 (752)	262 (578)	548 (1,208)	442 (974)	343 (756)	754 (1,663)	605 (1,334)	474 (1,045)
0,0 m (0.0 in)	422 (931)	278 (613)	210 (463)	-	-	-	502 (1,107)	328 (723)	249 (549)	643 (1,418)	420 (926)	322 (710)	889 (1,960)	574 (1,266)	443 (977)
-1,0 m (-39 in)	445 (981)	355 (783)	271 (598)	-	-	-	-	-	-	561 (1,237)	421 (928)	323 (712)	758 (1,671)	578 (1,275)	447 (986)
-1,5 m (-59 in)	446 (983)	446 (983)	446 (983)	-	-	-	-	-	-	-	-	-	386 (851)	386 (851)	386 (851)

Tab.3: Hubkrafttabellen ET20 Oberwagen nicht gekippt, - Kabine,Telefahrwerk und VDS mit kurzem Löffelstiel















A B				3,0 m (9'-10")			2,5 m (98 in)			2,0 m (79 in)			1,5 m (59m)		
															
2,5 m (98 in)	341 (752)	312 (688)	240 (529)	-	-	-	325 (717)	325 (717)	280 (617)	-	-	-	-	-	-
2,0 m (79 in)	346 (763)	274 (604)	209 (461)	-	-	-	338 (745)	338 (745)	276 (609)	341 (752)	341 (752)	341 (752)	-	-	-
1,0 m (39 in)	362 (798)	244 (538)	183 (404)	375 (827)	268 (591)	202 (445)	420 (926)	337 (743)	258 (569)	502 (1,107)	439 (968)	341 (752)	675 (1,488)	608 (1,340)	477 (1,052)
0,0 m (0.0 in)	385 (849)	250 (551)	187 (412)	400 (882)	259 (571)	194 (428)	336 (741)	321 (708)	242 (534)	475 (1,047)	412 (909)	314 (692)	872 (1,923)	565 (1,246)	433 (955)
-1,0 m (-39 in)	411 (906)	309 (681)	233 (514)	-	-	-	437 (964)	320 (705)	241 (531)	586 (1,292)	409 (902)	310 (684)	794 (1,751)	563 (1,241)	432 (953)
-1,5 m (-59 in)	419 (924)	396 (873)	302 (666)	-	-	-	-	-	-	443 (977)	418 (922)	319 (703)	648 (1,429)	574 (1,265)	442 (975)

Tab.4: Hubkrafttabellen ET20 Oberwagen gekippt, - Kabine,Telefahrwerk und VDS mit langem Löffelstiel

















**WACKER
NEUSON**
all it takes!

Hubkrafttabellen ET20 – Oberwagen nicht gekippt

A B		3,5 m (11'-6")			3,0 m (9'-10")			2,5 m (98 in)			2,0 m (79 in)				
															
2,5 m (98 in)	382 (842)	329 (725)	298 (657)	-	-	-	385 (849)	323 (712)	292 (644)	355 (783)	355 (783)	355 (783)	-	-	-
2,0 m (79 in)	383 (845)	281 (620)	254 (560)	-	-	-	378 (834)	323 (712)	292 (644)	384 (847)	384 (847)	384 (847)	-	-	-
1,0 m (39 in)	397 (875)	242 (533)	218 (481)	399 (880)	244 (538)	220 (485)	445 (981)	307 (677)	277 (611)	532 (1,173)	400 (882)	359 (792)	722 (1,592)	549 (1,211)	491 (1,083)
0,0 m (0.0 in)	420 (926)	245 (540)	220 (485)	-	-	-	501 (1,105)	293 (646)	263 (580)	639 (1,409)	376 (829)	336 (741)	887 (1,956)	513 (1,131)	456 (1,006)
-1,0 m (-39 in)	443 (977)	305 (673)	274 (604)	-	-	-	-	-	-	578 (1,275)	374 (825)	335 (739)	778 (1,716)	515 (1,136)	458 (1,010)
-1,5 m (-59 in)	442 (975)	402 (886)	360 (794)	-	-	-	-	-	-	-	-	-	608 (1,341)	526 (1,160)	468 (1,032)

Tab.5: Hubkrafttabellen ET20 Oberwagen gekippt, – Canopy und Telefahrwerk mit kurzem Löffelstiel

















A B		3,5 m (11'-6")			3,0 m (9'-10")			2,5 m (98 in)			2,0 m (79 in)				
															
2,5 m (98 in)	341 (752)	289 (637)	261 (576)	-	-	-	326 (719)	324 (714)	293 (646)	-	-	-	-	-	-
2,0 m (79 in)	345 (761)	250 (551)	226 (498)	-	-	-	334 (737)	321 (708)	290 (640)	330 (728)	330 (728)	330 (728)	-	-	-
1,0 m (39 in)	360 (794)	218 (481)	195 (430)	370 (816)	239 (527)	215 (474)	411 (906)	303 (668)	272 (600)	485 (1,069)	397 (875)	357 (787)	639 (1,409)	552 (1,217)	493 (1,087)
0,0 m (0.0 in)	382 (842)	220 (485)	196 (432)	400 (882)	230 (507)	206 (454)	484 (1,067)	285 (628)	255 (562)	616 (1,358)	368 (811)	328 (723)	863 (1,903)	504 (1,111)	447 (986)
-1,0 m (-39 in)	407 (897)	265 (584)	237 (523)	-	-	-	451 (995)	283 (624)	253 (558)	596 (1,314)	362 (798)	322 (710)	808 (1,782)	500 (1,103)	443 (977)
-1,5 m (-59 in)	416 (917)	331 (730)	296 (653)	-	-	-	-	-	-	492 (1,085)	369 (814)	329 (725)	679 (1,497)	508 (1,120)	451 (995)

Tab.6: Hubkrafttabellen ET20 Oberwagen gekippt, – Canopy und Telefahrwerk mit langem Löffelstiel



















**WACKER
NEUSON**
all it takes!

Hubkrafttabellen ET20 – Oberwagen nicht gekippt

A B				3,0 m (9'-10")			2,5 m (98 in)			2,0 m (79 in)			1,5 m (59 in)		
															
2,5 m (98 in)	380 (838)	326 (719)	248 (547)	-	-	-	378 (834)	332 (732)	253 (558)	356 (785)	356 (785)	349 (770)	-	-	-
2,0 m (79 in)	383 (845)	282 (622)	212 (468)	-	-	-	380 (838)	331 (730)	251 (554)	394 (869)	394 (869)	341 (752)	-	-	-
1,0 m (39 in)	399 (880)	248 (547)	182 (401)	401 (884)	251 (554)	185 (408)	452 (996)	315 (695)	236 (520)	548 (1,208)	409 (902)	310 (683)	754 (1,662)	562 (1,239)	429 (946)
0,0 m (0.0 in)	422 (931)	256 (565)	187 (412)	-	-	-	502 (1,107)	302 (666)	223 (492)	643 (1,418)	388 (856)	288 (635)	889 (1,960)	531 (1,171)	398 (878)
-1,0 m (-39 in)	445 (981)	328 (723)	243 (536)	-	-	-	-	-	-	561 (1,237)	389 (858)	289 (637)	758 (1,671)	535 (1,180)	402 (886)
-1,5 m (-59 in)	446 (983)	446 (983)	446 (983)	-	-	-	-	-	-	-	-	-	386 (851)	386 (851)	386 (851)

Tab.7: Hubkrafttabellen ET20 Oberwagen gekippt, – Canopy, Telefahrwerk und VDS mit kurzem Löffelstiel

A B				3,0 m (9'-10")			2,5 m (98 in)			2,0 m (79 in)			1,5 m (59 in)		
															
2,5 m (98 in)	341 (752)	288 (635)	216 (477)	-	-	-	325 (717)	325 (717)	254 (560)	-	-	-	-	-	-
2,0 m (79 in)	346 (763)	253 (558)	187 (412)	-	-	-	338 (745)	329 (725)	250 (551)	341 (752)	341 (752)	341 (752)	-	-	-
1,0 m (39 in)	362 (798)	224 (494)	162 (357)	375 (827)	246 (542)	180 (397)	420 (926)	311 (686)	232 (512)	502 (1,107)	407 (897)	308 (679)	675 (1,488)	564 (1,244)	432 (953)
0,0 m (0.0 in)	385 (849)	230 (507)	165 (364)	400 (882)	238 (525)	172 (379)	336 (741)	295 (651)	216 (476)	475 (1,047)	380 (838)	281 (620)	872 (1,923)	521 (1,149)	388 (855)
-1,0 m (-39 in)	411 (906)	284 (626)	207 (456)	-	-	-	437 (964)	294 (648)	215 (474)	586 (1,292)	377 (831)	277 (611)	794 (1,750)	520 (1,147)	387 (853)
-1,5 m (-59 in)	419 (924)	365 (805)	271 (597)	-	-	-	-	-	-	443 (977)	385 (849)	286 (631)	648 (1,429)	530 (1,169)	397 (875)

Tab.8: Hubkrafttabellen ET20 Oberwagen gekippt, – Canopy, Telefahrwerk und VDS mit langem Löffelstiel



Hubkrafttabellen ET20 – Oberwagen gekippt

A \ B			3,0 m (9'-10")		2,5 m (98 in)		2,0 m (79 in)		1,5 m (59 in)	
	kurzer Löffelstiel	langer Löffelstiel	kurzer Löffelstiel	langer Löffelstiel	kurzer Löffelstiel	langer Löffelstiel	kurzer Löffelstiel	langer Löffelstiel	kurzer Löffelstiel	langer Löffelstiel
2,5 m (98 in)	328 (723)	293 (646)	-	-	354 (781)	326 (719)	364 (804)	310 (683)	-	-
2,0 m (79 in)	291 (642)	263 (580)	-	271 (598)	350 (772)	348 (767)	415 (915)	362 (798)	467 (1,030)	-
1,0 m (39 in)	264 (582)	239 (527)	267 (589)	262 (578)	334 (737)	329 (725)	431 (950)	427 (942)	588 (1,297)	588 (1,296)
0,0 m (0.0 in)	280 (617)	251 (554)	-	255 (562)	323 (712)	315 (695)	413 (911)	404 (891)	565 (1,246)	554 (1,222)
-1,0 m (-39 in)	379 (836)	325 (717)	-	-	-	-	418 (922)	405 (893)	573 (1,264)	557 (1,128)
-1,5 m (-59 in)	427 (942)	417 (920)	-	-	-	-	-	-	438 (966)	570 (1,257)

Tab.9: Hubkrafttabellen ET20 Oberwagen gekippt, – VDS, Kabine, Armsystem bergauf

A \ B			3,0 m (9'-10")		2,5 m (98 in)		2,0 m (79 in)		1,5 m (59 in)	
	kurzer Löffelstiel	langer Löffelstiel	kurzer Löffelstiel	langer Löffelstiel	kurzer Löffelstiel	langer Löffelstiel	kurzer Löffelstiel	langer Löffelstiel	kurzer Löffelstiel	langer Löffelstiel
2,5 m (98 in)	261 (575)	232 (512)	-	-	282 (622)	282 (622)	364 (803)	310 (684)	-	-
2,0 m (79 in)	231 (509)	207 (456)	-	214 (471)	278 (613)	276 (609)	368 (811)	362 (798)	467 (1,030)	-
1,0 m (39 in)	208 (459)	187 (412)	210 (463)	205 (452)	263 (580)	258 (569)	338 (745)	334 (737)	455 (1,003)	454 (1,001)
0,0 m (0.0 in)	220 (485)	195 (430)	-	198 (437)	252 (556)	244 (538)	321 (708)	312 (688)	433 (955)	423 (933)
-1,0 m (-39 in)	297 (655)	253 (558)	-	-	-	-	326 (719)	313 (690)	441 (972)	426 (939)
-1,5 m (-59 in)	427 (942)	345 (761)	-	-	-	-	-	-	438 (966)	439 (968)

Tab.10: Hubkrafttabellen ET20 Oberwagen gekippt, – VDS, Kabine, Armsystem bergab



**WACKER
NEUSON**

all it takes!

Hubkrafttabellen ET20 – Oberwagen gekippt

A \ B			3,0 m (9'-10")		2,5 m (98 in)		2,0 m (79 in)		1,5 m (59 in)	
	kurzer Löffelstiel	langer Löffelstiel	kurzer Löffelstiel	langer Löffelstiel	kurzer Löffelstiel	langer Löffelstiel	kurzer Löffelstiel	langer Löffelstiel	kurzer Löffelstiel	langer Löffelstiel
2,5 m (98 in)	304 (670)	271 (598)	-	-	328 (723)	326 (719)	364 (803)	310 (684)	-	-
2,0 m (79 in)	269 (593)	242 (534)	-	250 (551)	324 (714)	322 (710)	415 (915)	362 (798)	467 (1,030)	-
1,0 m (39 in)	243 (536)	219 (483)	246 (542)	241 (531)	308 (679)	303 (668)	398 (878)	395 (871)	544 (1,200)	545 (1,202)
0,0 m (0.0 in)	258 (569)	231 (509)	-	234 (516)	297 (655)	289 (637)	381 (840)	372 (820)	521 (1,148)	511 (1,127)
-1,0 m (-39 in)	350 (772)	299 (659)	-	-	-	-	386 (851)	373 (823)	530 (1,169)	514 (1,133)
-1,5 m (-59 in)	427 (942)	410 (904)	-	-	-	-	-	-	438 (966)	528 (1,164)

Tab.11: Hubkrafttabellen ET20 Oberwagen gekippt, – VDS, Kabine, Armsystem bergauf

A \ B			3,0 m (9'-10")		2,5 m (98 in)		2,0 m (79 in)		1,5 m (59 in)	
	kurzer Löffelstiel	langer Löffelstiel	kurzer Löffelstiel	langer Löffelstiel	kurzer Löffelstiel	langer Löffelstiel	kurzer Löffelstiel	langer Löffelstiel	kurzer Löffelstiel	langer Löffelstiel
2,5 m (98 in)	241 (531)	213 (470)	-	-	261 (575)	260 (573)	351 (774)	310 (684)	-	-
2,0 m (79 in)	212 (468)	189 (417)	-	196 (432)	257 (567)	255 (562)	341 (752)	341 (752)	467 (1,030)	-
1,0 m (39 in)	190 (419)	170 (375)	193 (426)	187 (412)	241 (531)	237 (523)	311 (686)	308 (679)	419 (924)	419 (924)
0,0 m (0.0 in)	201 (443)	178 (392)	-	180 (397)	231 (509)	223 (492)	294 (648)	286 (631)	398 (878)	387 (853)
-1,0 m (-39 in)	273 (602)	231 (509)	-	-	-	-	299 (659)	286 (631)	406 (895)	390 (860)
-1,5 m (-59 in)	414 (913)	317 (699)	-	-	-	-	-	-	423 (933)	403 (889)

Tab.12: Hubkrafttabellen ET20 Oberwagen gekippt, – VDS, Kabine, Armsystem bergab