

---

# PR 776 Litronic

---

## LIEBHERR

Mining dozer



**Operating weight**

71.8–73.2 tonnes  
79.1–80.6 tons

**Engine power**

440 kW / 598 HP Forward  
565 kW / 768 HP Reverse  
Tier 2  
Stage V / Tier 4f

## Overview

# PR 776



440 kW / 598 HP Forward  
565 kW / 768 HP Reverse



Semi-U Blade 18.5 m<sup>3</sup> / 24.2 yd<sup>3</sup>  
U Blade 22.0 m<sup>3</sup> / 28.8 yd<sup>3</sup>



71.8–73.2 tonnes  
79.1–80.6 tons

Hydrostatic travel drive  
with electronic control unit



## Productivity

Working harder and faster

## Efficiency

Moving more for less

## Reliability

Ready to work when you need it



## Customer service

World-class support, everywhere, every day

## Safety

Protecting your most important assets

## Environment

Mining responsibly

# Productivity



## Working harder and faster

Powerful and innovative technologies are the essential hallmarks of Liebherr mining dozers. Either while pushing or ripping, the PR 776 is an extremely powerful machine for any application.



### Intelligent engine control

- The electronically controlled power and torque characteristics provide excellent traction and rapid response
- A requirements-driven increase in power ensures sufficient power reserves, even in the most arduous workplace situations
- When reversing on steep terrain, enough engine power is provided to enable the vehicle to achieve high travelling speeds and short cycle times





## High productivity

### Powerful engine

The Liebherr diesel engine is designed for tough mining and extraction operations, and provides sufficient power to contend with any situation. Different operating modes are available, including maximum power or fuel-saving, depending on the job requirements.

### An intelligent drive system

The hydrostatic travel drive operates smoothly and automatically adjusts the working speed to the load conditions. The torque is constant on both tracks without interruption. This allows exact and powerful steering. Track slip is minimised and operators can fully concentrate on their job.

### Excellent maneuverability

When working in narrow areas, the hydrostatic travel drive offers an additional benefit. All steering motions – including turning on the spot – are fast and precise. When involved in ripping work, the ripper can be positioned precisely to enable it to apply great power when ripping layers of hard rock.

### Best traction and lowest vibration levels

Pendulum-mounted track rollers and idlers provide good traction and reduce vibration levels on the mining dozer.

### Outstanding grading attributes

Mining dozers in all size classes must provide maximum versatility. The PR 776 delivers an exceptionally smooth ride, precise blade control and a perfect view on the blade corners. It therefore is able to deliver optimum productivity during heavy-duty pushing operations, when preparing loading platforms for mining excavators and when building and maintaining haul roads.

### High blade penetration forces

The blade on the PR 776 is mounted very close to the main frame. This achieves maximum force and assures optimum filling of the blade.

### Visible productivity benefit

The optional GPS navigation system displays the status of works in progress, as well as the surrounding terrain. This allows the operator to fully focus, achieving maximum productivity.

### Liebherr-hydrostatic drive

- Infinitely variable travel speeds
- Continuous power flow – no interruption in traction
- Continuous power transmission to both tracks during steering
- Superior manoeuvrability, including turning on the spot
- No gears and constant engine speed
- Zero-wear service brake system with automatically activated parking brake

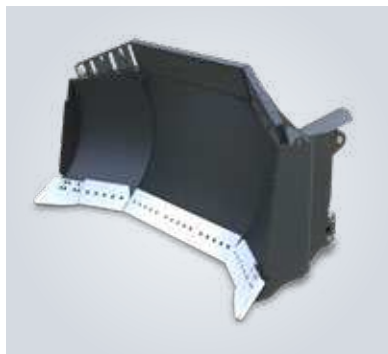

### Application-optimized dozer blade shape

- Intensive development work and field measurements have produced the dozer blade surface areas and shapes to perfectly suit the basic machine. They provide the best material rolling properties on self-bonding materials as well as high fill levels for dozer blades when pushing heavy masses of rock

# Efficiency



## Moving more for less

Liebherr mining dozers are designed with efficiency in mind. Highly efficient drive concept, long service life of components and low maintenance requirements reduce operating costs and increase profits.



### Eco-mode

- The standard ECO function enables the driver to choose between high productivity and maximum efficiency. Consequently, during light and medium duty operations the ECO function further improves operational efficiency and saves fuel in the process
- Additional optional functions, such as the auto-idle function or automatic engine shut-down, further contribute to fuel efficiency



### Intelligent cooling system

- Electronically controlled suction fans regulate the operating temperatures of hydraulic fluid and engine. The individual components are maintained within an ideal temperature range at all times. This protects the components and extends their service life. The cooling air is drawn in from clean areas which reduces contamination levels
- Optionally, Liebherr can provide reversible fans for automatic self-cleaning of the radiator in very dusty working environments



## Fast component replacement

As part of the development work on the PR 776, Liebherr always ensures that all important components can be replaced quickly and easily, and sent in to the Liebherr Reman programme for reconditioning. For example, the Liebherr travel drives and their oil motors can be dismantled easily from one side when required. In the same way, the folding front section on the chassis provides optimum access to the engine. This makes it possible to remove and reinstall the radiator and the Liebherr diesel engine quickly.

### Load sensing working hydraulics

The system always provides the amount of power actually needed by the operating hydraulics. If the equipment is not being actuated, fuel is being saved.

### Long service intervals

With Liebherr hydraulic fluids, service intervals of up to 6,000 hours can be achieved. If Liebherr Plus oils are used, this extends service intervals to as much as 8,000 hours of operation. Maintenance times are reduced substantially which improves machine availability, respectively the dozer uptime. Liebherr oils reduce fuel consumption by cutting down on the resistance levels of moving parts. These oils also provide high-calibre corrosion protection and optimum compatibility with hydraulic hoses, seals and gaskets.

### Always informed with LiDAT

- Evaluations of machine utilisation and fuel consumption deliver cost-effective machine management
- Effective fleet management by data transmission and positioning system
- Monitoring of important machine parameters



## Unrivalled efficiency

### State of the art engine technology

The latest generation of Liebherr diesel engines is characterised by an extremely low level of fuel consumption. The consistently, low engine speed in conjunction with Common-Rail fuel injection, leads to optimized cylinder management and very efficient combustion of fuel. This keeps the engine performing at a consistently efficient rate at all times.

### Highly efficient driveline

The high efficiency rating of the hydrostatic drive across the entire vehicle speed range and the efficient Liebherr diesel engine minimise fuel consumption and ensure that CO<sub>2</sub> emission levels are low.

### Efficient cooling system

Hydrostatic fans and coolers with widely spaced louvre slats deliver optimum cooling power in very dusty work environments. Requirements-based speed adaptation and flow-optimised fan blades result in fuel savings and minimal noise emissions.

### Tilting cab

The standard cab can be tilted, if required, allowing quick and easy access to all components of the hydrostatic travel drive. This saves time and increases machine availability.

# Reliability

---



## Ready to work when you need it

The mining industry imposes very high demands on the productivity and reliability of the machines and vehicles it uses. The PR 776 meets these demands perfectly. Its components were specifically developed for arduous working environments. The same is true of its carefully crafted technology, innovation, and detailed solutions, all of which combine to deliver ultimate levels of operational availability.



## Liebherr driveline

### Robust engines

Diesel engines from Liebherr have powered machinery around the world for decades. Developed for the harshest operating conditions, the robust build and state-of-the-art technology of these engines ensure optimum operational safety and long service life.

### Wear-free drive concept

The hydrostatic Liebherr travel drive does not require any components such as a torque converter, multi-ratio transmission, service brakes or steering couplings. The high-quality hydraulic pumps and motors operate reliably and practically without wear.

### Generously dimensioned final drives with automatic temperature monitoring

The durable final drives are extremely robust and have been designed to cope with exceptionally high loads. The double transmission seal with continuous temperature monitoring ensures reliable operation.

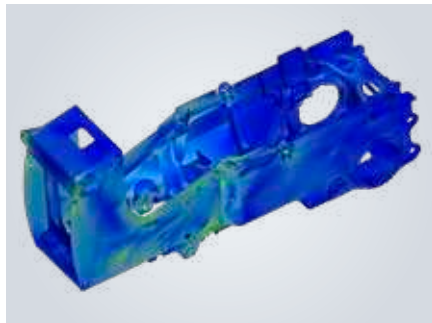

### Designed for the harshest applications

- Optimised layout: at the development stage components are designed with state-of-the-art software tools
- Extensive test bench runs are the next important step in the development process
- Long-term field tests under rigorous conditions ensure maximum machine availability

### Liebherr component integration

- Liebherr has decades of experience in developing, designing and manufacturing components and, as a result, offers maximum reliability
- Important key components such as diesel engines, splitter box, hydraulic pumps and -motors, hydraulic cylinders, final drives and electronics are manufactured in our own facilities, optimized for combined operation and representing the highest quality

## Solutions for continuous operation

### Main frame with a proven box-section design

The main frame is constructed using a proven box-section design, which provides maximum torsional stiffness and optimal absorption of forces. Cast steel is used for components subjected to high stress.

### Optimised equipment

Liebherr blades are manufactured using high-quality steels and are based on a modular design principle. The robust blade mountings provide optimum rigidity and enable the blade to be guided precisely. All rear-mounted ripper variants are designed for heavy-duty mining operations and deliver very high penetration forces. In addition, exposed areas such as bolt connections are protected by appropriate wear protection.

### Robust radiator version

For work in very dusty environments, reliable and corrosion-resistant radiators are used. The louvre slats on these are spaced widely at 8 mm. These offer optimum protection against dirt and environmental influences.

### Options for arctic and high altitude package

For operation at low temperatures and high altitudes, Liebherr can provide a number of proven ex-factory adaptations.

### The right configuration for tough and abrasive operations

- The combined overflow panel with rock guard offers optimum protection for the radiator and also gives the driver excellent visibility to the material in the dozer blade
- For very abrasive operations, there is the option of fitting ultra-wear-resistant steel panels to the blade, to the dozer push frame and to the hydraulic tilt and pitch cylinders

# Customer service



## Cost-effective maintenance

### Simple daily checks

All items that the operator checks during daily routine inspections are readily accessible on one side of the engine. The hydraulically tilted cab provides easy access to components as well. Service work can be performed quickly and efficiently.

### Long maintenance intervals

The maintenance intervals are perfectly matched to suit individual components. In exposed areas zero-maintenance bearings are used. Particularly long maintenance intervals for engine oil and hydraulic fluid help reduce costs and increase availability, respectively.

## Optimal planning

### Planned costs

Liebherr mining dozers come with extensive standard warranties for the entire machine and the drive train. Customised inspection and service programs allow optimal planning of all maintenance activities.

### Remanufacturing

The Liebherr-Reman Programme provides a cost-effective way of upgrading components to meet the stringent quality standards of the originally manufactured equipment. Various reconditioning levels are available including replacement components and general overhaul or repair. This assures the customer the most economical and highest quality component for the service life of the machine.

## The focus is on the customer

### Professional advice and service

Professional advice is given at Liebherr. Experienced specialists provide guidance for your specific requirements including application-oriented service support, service agreements, value-priced repair alternatives, original parts management, as well as remote data transmission for machine planning and fleet management.

### Continuous dialog with users

We utilise the expert knowledge and practical experience of our customers to continuously optimise our machines and services – real solutions for real situations.



## World-class support, everywhere, every day

Thanks to their minimal maintenance requirements, Liebherr mining dozers make a reliable contribution to your economic success. The extensive network of highly professional Liebherr Service Centres mean that mining customers can obtain assistance rapidly and locally.



### Easy access

- All service points are centrally located and easily accessible. Thanks to wide-opening access doors, routine inspection of the machine is easily performed
- Lube points for the equalizer bar are arranged conveniently inside the engine compartment
- The standard lighting inside the engine compartment is a great help for maintenance and servicing work



### Hinged cooling fan

- In very dusty working environments, the hinged guard makes it a great deal easier to clean the radiator system. The radiator shroud can be lifted up after unfastening just a few screws
- On the PR 776, as a standard feature, the hydraulic oil cooling fans can be opened up for cleaning without the need for tools



### Expedited spare parts service

- 24-hour delivery – spare parts service is available for our dealers around the clock
- The electronic spare parts catalogue allows fast and reliable selection and ordering via the Liebherr online portal
- With online tracking the current processing status of your order can be viewed at any time

# Safety

---



## Protecting your most important assets

The Liebherr PR 776 offers an uncompromising safety concept for drivers and for service personnel. Maintenance and service points are readily accessible and this, in conjunction with wide-opening covers, enables maintenance and service work to be carried out rapidly and safely. Moreover, the cab on the PR 776 offers a wide range of safety features.

# Highest safety standards

## Best all-round visibility with integrated ROPS / FOPS protection

A new feature in this machine class is the ROPS / FOPS protection integrated directly in the cab structure of Liebherr mining dozers. This provides perfect all-round visibility, substantially improving productivity and, even more importantly, improving workplace safety.

## Rear-view camera

The image from the standard reversing camera is integrated directly in the front display and this switches into full-screen mode automatically whenever the dozer is reversing. This offers an optimum level of safety and comfort.

## Working platforms

To make inspection and service work as convenient as possible for maintenance personnel, an optional working platform with handrail can be supplied. Access to components like the air-con unit, oil cooler and electronics is therefore a very safe process.

## Lighting for the access steps

From ground level, the driver can activate the access steps lighting. This lights up the entire area for the left-hand access steps.

## Optional powered access ladder

Enhance safety during shift changes and maintenance schedules by facilitating easy access to the machine's catwalk.

## Automatic parking brake

When the machine is stationary, the parking brake is activated automatically. This prevents the machine from rolling away. The zero-wear parking brake releases automatically whenever the dozer starts travelling, making operation even more convenient.

## Safe access to the workplace and the service points

Readily accessible and ergonomic handles with non-slip access steps make the driver's cab easy and safe to enter and leave.



## Optimum visibility

- The PR 776 offers optimum visibility to all sides, even with the optional work platform installed. People and obstacles can be detected very well. Especially in mining applications, this feature contributes substantially to enhanced safety
- The containers with sloping edges provide clear visibility of areas close to the machine

## Ground-level operating panel

- The operating panel is easy to reach from ground-level, and this makes it possible to activate the cab access step lighting
- It is also a quick and safe operation to speed-fill the fuel tank on this dozer
- The emergency-stop button integrated directly in the control panel can be operated at any time to shut down the entire unit

## Modern lighting concept

- To provide optimum illumination of the working area, there is a choice of modern lighting, e.g. high-performance LEDs
- The modular lighting concept is part of the new machine design and it makes it possible to match the lighting to each application in an optimum manner

# Environment



## Mining responsibly

Liebherr considers the conservation and preservation of the environment as a major challenge for the present and future. Liebherr are considerate of environmental issues in designing, manufacturing and managing machine structures, providing solutions that allow customers to balance performance with environmental consciousness.

### Minimized impact on life

#### Optimized energy consumption, fewer emissions

Constant power regulation of the hydraulic system and engine output optimize equipment fuel efficiency, depending on the application. In “Eco-Mode” setting, the machine is set up to reduce engine load, significantly improve fuel consumption and reduce emissions.

#### Controlled emission rejection

The PR 776 is powered by a high horsepower diesel engine which complies with the US EPA Tier 2 or US EPA Tier 4f / EU Stage V compliant emission limits. This power drive makes the PR 776 cost-effective, without compromising productivity, and reduces the machines impact on the environment.

\*REACH is the European Community Regulation on chemicals and their safe use (EC 1907/2006). It deals with the Registration, Evaluation, Authorization and Restriction of Chemical Substances.

### Sustainable design and manufacturing process

#### Certified environment management systems

Subject to the stringent European program for the regulation of the use of chemical substances in the manufacturing process REACH\*, Liebherr undertakes a global evaluation to minimize the impacts of hazardous material, pollution control, water conservation, energy and environmental campaigns.

#### Extended components and fluids lifetime

Liebherr is constantly working on ways to extend component life. Through the Exchange Components program, superior lubrication systems and the reinforcement of parts under stress, Liebherr can reduce frequency of part replacement. The result minimizes environmental impact and lowers the overall total cost of ownership.



**The Liebherr-Mining remanufacturing program**

- Reduced environmental impact
- Second life for your components
- Reduced costs and investment
- Liebherr certified workshops
- Alternative to purchase brand-new replacement components



**Eco-Mode**

Eco-Mode can be manually selected by the operator when maximum power is not required, dependent upon the job needs:

- Less fuel consumption
- Less load on the engine
- Less noise pollution
- Less dioxide carbon emissions



**Automatic idle control**

Electronic idle control of the engine results in:

- Less fuel consumption
- Less load on the engine
- Reduced emissions
- More comfort to the operator (reduced noise pollution)

# Technical data



## Engine

|   |  |
|---|--|
| <b>Liebherr Diesel engine</b>   | D 9512 A7<br>Emission regulations according to 97/68/EC, 2004/26/EG Stage V, EPA/CARB Tier 4f or Tier 2                              |
| <b>Rated power (net)</b><br>ISO 9249<br>FDW / REV<br>SAE J1349<br>FDW/REV     | 440 / 565 kW / 598 / 768 HP<br>440 / 565 kW / 590 / 757 HP   |
| <b>Maximum power (net)</b><br>ISO 9249<br>FDW / REV<br>SAE J1349<br>FDW / REV | 506 / 565 kW / 687 / 768 HP<br>506 / 565 kW / 678 / 757 HP   |
| <b>Rated speed</b>  | 1,600 rpm  |
| <b>Displacement</b>   | 24.2l / 1,477 in <sup>3</sup>  |
| <b>Design</b>   | 12 cylinder V-engine, water-cooled, turbocharged, air-to-air intercooler   |
| <b>Injection system</b>   | Direct fuel injection, Common Rail, electronic control   |
| <b>Lubrication</b>  | Pressurised lube system, engine lubrication guaranteed for inclinations up to 35° (lateral slope) and up to 45° (longitudinal slope) |
| <b>Electrical system</b>  |  |
| <b>Operating voltage</b>  | 24 V   |
| <b>Alternator</b>   | 24 V / 140 A   |
| <b>Starter</b>  | 24 V / 2 x 8.4 kW / 11 HP  |
| <b>Batteries</b>  | 4 x 180 Ah / 12 V  |
| <b>Air cleaner</b>  | Dry-type air cleaner with pre-cleaner, main and safety elements, control light in the operator's cab                                 |
| <b>Cooling system</b>   | Combi radiator, comprising a radiator for coolant and charge air. Hydrostatic fan drive  |



## Hydraulics

|                         |   |
|-------------------------|---|
| <b>Hydraulic system</b> | Load sensing (demand-controlled)  |
| <b>Pump type</b>        | Swash plate piston pump   |
| <b>Max. Pump flow</b>   | 352l/min. / 92.9 gpm  |
| <b>Max. Pressure</b>    | 260 bar / 3,770 psi   |
| <b>Control valve</b>    | 4 segments, expandable  |
| <b>Filter system</b>    | Return filter with magnetic rod in the hydraulic tank                               |
| <b>Control</b>          | Single joystick for all blade functions<br>Single joystick for all ripper functions |



## Travel drive

|   |   |
|---|---|
| <b>Transmission system</b>                              | Infinitely variable hydrostatic travel drive, independent closed loop system for each track                 |
| <b>Travel speed</b><br>max. speed FWD<br>max. speed REV | Continuously variable<br>10.5 km/h<br>10.5 km/h   |
| <b>Electronic control</b>                               | The electronic system automatically adjusts travel speed and drawbar pull to match changing load conditions |
| <b>Steering</b>   | Hydrostatic   |
| <b>Service brake</b>                                    | Hydrostatic (self-locking), wear-free   |
| <b>Parking brake</b>                                    | Multi-disk brake, wear-free, automatically applied with neutral joystick position                           |
| <b>Cooling system</b>                                   | Two separate hydraulic oil coolers, hydrostatic fan drives  |
| <b>Filter system</b>                                    | Micro cartridge filters in replenishing circuit   |
| <b>Final drive</b>                                      | Combination spur gear with planetary gear, double-sealed (duo cone seals), temperature controlled           |
| <b>Control</b>  | Single joystick for all travel and steering functions   |



## Operator's cab

|  |  |
|--|--|
| <b>Design</b>                            | Resiliently mounted cab with positive pressure ventilation, can be tilted with hand pump 40° to the rear. With integrated ROPS Rollover Protective Structure (EN ISO 3471) and FOPS Falling Objects Protective Structure (EN ISO 3449) |
| <b>Operator's seat</b>                   | Air-suspended and heated comfort seat, fully adjustable  |
| <b>Monitoring</b>                        | Touch screen: display of current machine information, automatic monitoring of operating conditions. Individual setting of machine parameters   |
| <b>Display</b>                           | Color LCD-display with low and high brightness settings  |
| <b>Vision system</b>                     | Camera installation on the back of the dozer, displayed over the LCD-display   |
| <b>Heating system / Air conditioning</b> | Standard air conditioning, combined cooler / heater, additional dust filter in fresh air / recirculated  |
| <b>Vibration emission</b>                |  |
| Hand / arm vibrations                    | < 2.5 m/s <sup>2</sup> , according with ISO 5349-1:2001  |
| Whole-body vibrations                    | 0.24–1.31 m/s <sup>2</sup> , complies with technical report ISO/TR 25398:2006  |
| Measuring inaccuracy                     | According with standard EN 12096:1997  |



## Undercarriage

|                                     |  |
|-------------------------------------|--|
| <b>Design</b>                       | Undercarriage with oscillating idlers and rollers  |
| <b>Mounting</b>                     | Via separate pivot shafts and equalizer bar  |
| <b>Track chains</b>                 | Lubricated, single-grouser track shoes, tensioning via a steel spring and grease tensioner |
| <b>Links, each side</b>             | 44   |
| <b>Track rollers, each side</b>     | 8  |
| <b>Sprocket segments, each side</b> | 5  |
| <b>Track shoes</b>                  | 610 mm / 24"   |
| <b>Track shoe type</b>              | SESS (Super Extrem Service Shoes)  |

## Sound levels

|   |           |
|---|-----------|
| <b>Operator sound exposure ISO 6396</b>   |           |
| $L_{pA}$ (in the cab)                     | 76 dB(A)  |
| <b>Exterior sound pressure 2000/14/EC</b> |           |
| $L_{WA}$ (to the environment)             | 116 dB(A) |

## Electric system

|                                |  |
|--------------------------------|--|
| <b>Electric isolation</b>      | Lockable battery isolator switch   |
| <b>Working lights</b>          | <ul style="list-style-type: none"> <li>- 4 on the lifting cylinders (LED)</li> <li>- 4 on the cabin front (LED)</li> <li>- 2 on the rear console (LED)</li> <li>- 1 in the engine compartment</li> </ul> |
| <b>Emergency stop switches</b> | In the cab and on the ripper   |

## Refill capacities

|  |                     |
|--|---------------------|
| <b>Fuel tank</b>                       | 1,224 l / 323.3 gal |
| <b>Diesel Exhaust Fluid (DEF) tank</b> | 132 l / 34.9 gal    |
| <b>Cooling system</b>                  | 110 l / 29 gal      |
| <b>Engine oil with filter</b>          | 93 l / 24.6 gal     |
| <b>Splitter box</b>                    | 16 l / 4.2 gal      |
| <b>Hydraulic tank</b>                  | 320 l / 84.5 gal    |
| <b>Final drive, each side</b>          | 43 l / 11.4 gal     |

## Drawbar pull

|                              |        |
|------------------------------|--------|
| <b>Max.</b>                  | 955 kN |
| <b>at 1.5 km/h / 0.9 mph</b> | 842 kN |
| <b>at 3.0 km/h / 1.9 mph</b> | 452 kN |
| <b>at 6.0 km/h / 3.7 mph</b> | 226 kN |
| <b>at 9.0 km/h / 5.6 mph</b> | 151 kN |

# Dimensions

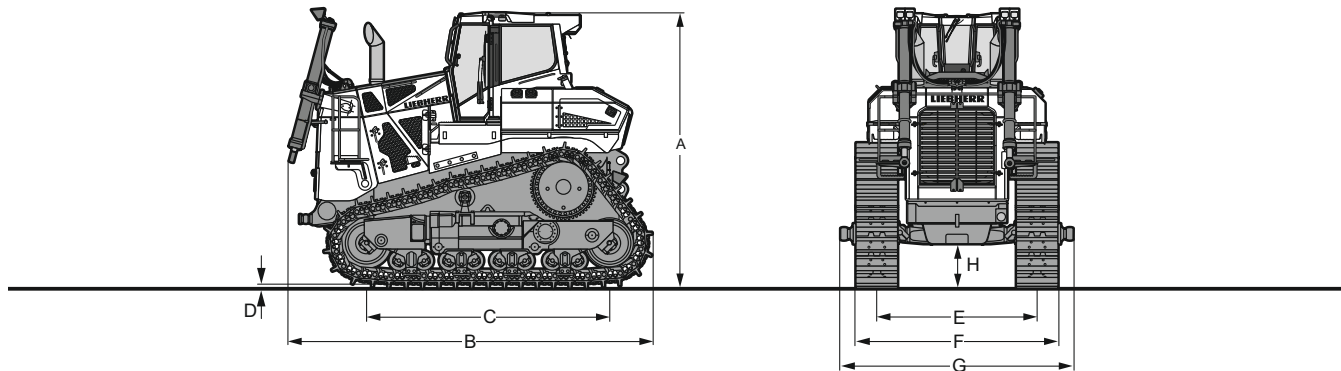

## Dimensions

|   |            |                  |
|---|------------|------------------|
| <b>A</b> Height over cab                    | mm         | 4,350            |
|   | ft in      | 14'3"            |
| <b>B</b> Overall length without attachments | mm         | 5,770            |
|   | ft in      | 18'11"           |
| <b>C</b> Length of track on ground          | mm         | 3,867            |
|   | ft in      | 12'8"            |
| <b>D</b> Height of grousers                 | mm         | 93               |
|   | ft in      | 3.6"             |
| <b>H</b> Ground clearance                   | mm         | 703              |
|   | ft in      | 2'4"             |
| <b>E</b> Track gauge                        | mm         | 2,550            |
|   | ft in      | 8'4"             |
| <b>G</b> Width over trunnions               | mm         | 3,715            |
|   | ft in      | 12'2"            |
| <b>F</b> Track shoes 610 mm / 24"           |            |                  |
| Width over tracks                           | mm / ft in | 3,160 / 10'4"    |
| Tractor shipping weight <sup>1)</sup>       | kg / lb    | 53,100 / 117,065 |
| <b>F</b> Track shoes 710 mm / 28"           |            |                  |
| Width over tracks                           | mm / ft in | 3,260 / 10'8"    |
| Tractor shipping weight <sup>1)</sup>       | kg / lb    | 53,744 / 118,485 |
| <b>F</b> Track shoes 762 mm / 30"           |            |                  |
| Width over tracks                           | mm / ft in | 3,310 / 10'10"   |
| Tractor shipping weight <sup>1)</sup>       | kg / lb    | 54,066 / 119,195 |

<sup>1)</sup> Including coolant and lubricants, 20% fuel, ROPS / FOPS cab.

# Front attachments

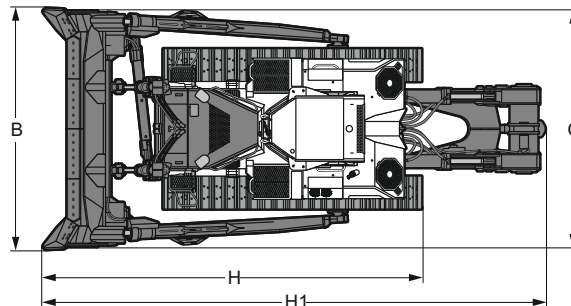
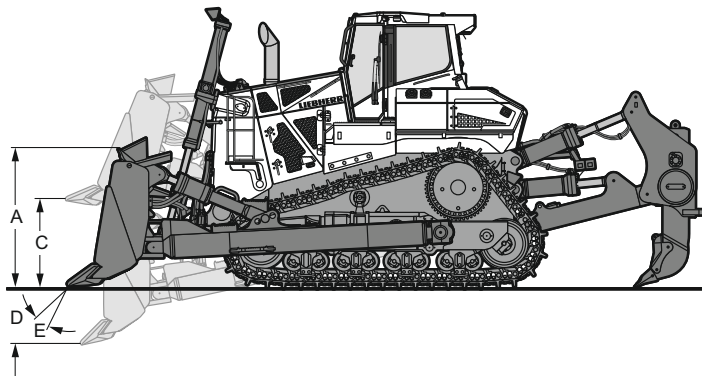

## Semi-U blade

|   |                                |                  |
|---|--------------------------------|------------------|
| <b>Blade capacity, ISO 9246</b>                                 | <b>m<sup>3</sup></b>           | 18.5             |
|   | <b>yd<sup>3</sup></b>          | 24.2             |
| <b>A Height of blade</b>  | <b>mm</b>                      | 2,125            |
|   | <b>ft in</b>                   | 7'               |
| <b>B Width of blade</b>   | <b>mm</b>                      | 4,830            |
|   | <b>ft in</b>                   | 15'10"           |
| <b>C Lifting height<sup>1)</sup></b>                            | <b>mm</b>                      | 1,565            |
|   | <b>ft in</b>                   | 5'2"             |
| <b>D Digging depth<sup>2)</sup></b>                             | <b>mm</b>                      | 670              |
|   | <b>ft in</b>                   | 2'2"             |
| <b>E Blade pitch adjustment</b>                                 |                                | 11°              |
| <b>Max. blade tilt</b>  | <b>mm</b>                      | 1,245            |
|   | <b>ft in</b>                   | 4'1"             |
| <b>G Width over push frame</b>                                  | <b>mm</b>                      | 4,674            |
|   | <b>ft in</b>                   | 15'4"            |
| <b>H Overall length, without ripper</b>                         | <b>mm</b>                      | 7,625            |
|   | <b>ft in</b>                   | 25'              |
| <b>H1 Overall length, with ripper in max. extended position</b> | <b>mm</b>                      | 10,094           |
|   | <b>ft in</b>                   | 33'1"            |
| <b>F Track shoes 610 mm / 24"</b>                               |                                |                  |
| Operating weight <sup>3)</sup>                                  | <b>kg / lb</b>                 | 71,800 / 158,292 |
| Ground pressure, ISO16754 <sup>3)</sup>                         | <b>kg/cm<sup>2</sup> / psi</b> | 1.52 / 21.61     |
| <b>F Track shoes 710 mm / 28"</b>                               |                                |                  |
| Operating weight <sup>3)</sup>                                  | <b>kg / lb</b>                 | 72,444 / 159,711 |
| Ground pressure, ISO16754 <sup>3)</sup>                         | <b>kg/cm<sup>2</sup> / psi</b> | 1.32 / 18.77     |
| <b>F Track shoes 762 mm / 30"</b>                               |                                |                  |
| Operating weight <sup>3)</sup>                                  | <b>kg / lb</b>                 | 72,766 / 160,421 |
| Ground pressure, ISO16754 <sup>3)</sup>                         | <b>kg/cm<sup>2</sup> / psi</b> | 1.24 / 17.63     |

<sup>1)</sup> With fully retracted tilt / pitch cylinders, the mechanical pitch adjustment bolted in the rear position and including the grouser height, the lifting height is 1,863 mm (6'1").

<sup>2)</sup> With mechanical pitch adjustment bolted in the rear position and including the grouser height, the digging depth is 501 mm (19.7").

<sup>3)</sup> Including coolant and lubricants, 100% fuel, ROPS / FOPS cab, operator, Semi U-blade with 1-shank ripper.

# Front attachments

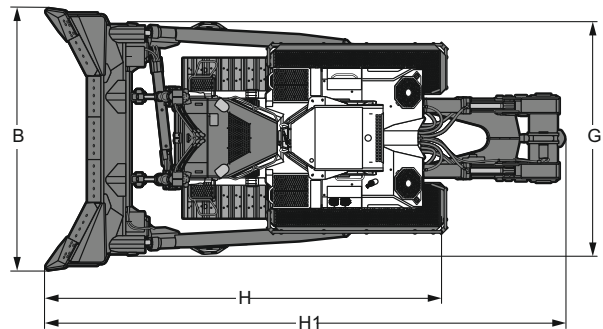
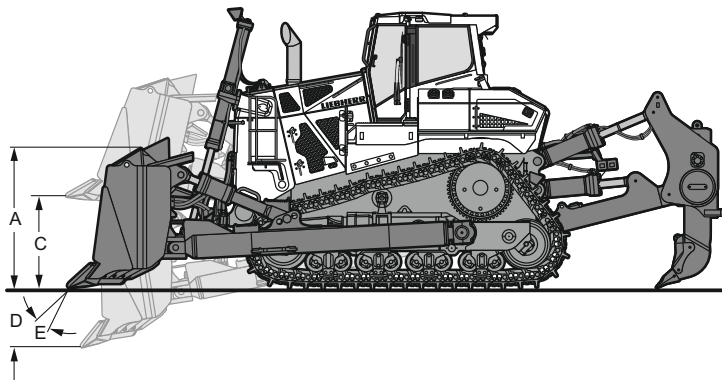

## U blade

|  |                                |                  |
|--|--------------------------------|------------------|
| <b>Blade capacity, ISO 9246</b>                                      | <b>m<sup>3</sup></b>           | 22.0             |
|  | <b>yd<sup>3</sup></b>          | 28.77            |
| <b>A Height of blade</b>   | <b>mm</b>                      | 2,125            |
|  | <b>ft in</b>                   | 7'               |
| <b>B Width of blade</b>  | <b>mm</b>                      | 5,270            |
|  | <b>ft in</b>                   | 17'3"            |
| <b>C Lifting height<sup>1)</sup></b>                                 | <b>mm</b>                      | 1,565            |
|  | <b>ft in</b>                   | 5'2"             |
| <b>D Digging depth<sup>2)</sup></b>                                  | <b>mm</b>                      | 670              |
|  | <b>ft in</b>                   | 2'2"             |
| <b>E Blade pitch adjustment</b>                                      |                                | 11°              |
| <b>Max. blade tilt</b>   | <b>mm</b>                      | 1,360            |
|  | <b>ft in</b>                   | 4'6"             |
| <b>G Width over push frame</b>                                       | <b>mm</b>                      | 4,674            |
|  | <b>ft in</b>                   | 15'4"            |
| <b>H Overall length, blade straight</b>                              | <b>mm</b>                      | 7,971            |
|  | <b>ft in</b>                   | 26'2"            |
| <b>H1 Overall length, with rear ripper in max. extended position</b> | <b>mm</b>                      | 10,440           |
|  | <b>ft in</b>                   | 34'3"            |
| <b>F Track shoes 610 mm / 24"</b>                                    |                                |                  |
| Operating weight <sup>3)</sup>                                       | <b>kg / lb</b>                 | 72,223 / 159,224 |
| Ground pressure, ISO16754 <sup>3)</sup>                              | <b>kg/cm<sup>2</sup> / psi</b> | 1.53 / 21.76     |
| <b>F Track shoes 710 mm / 28"</b>                                    |                                |                  |
| Operating weight <sup>3)</sup>                                       | <b>kg / lb</b>                 | 72,867 / 160,644 |
| Ground pressure, ISO16754 <sup>3)</sup>                              | <b>kg/cm<sup>2</sup> / psi</b> | 1.32 / 18.77     |
| <b>F Track shoes 762 mm / 30"</b>                                    |                                |                  |
| Operating weight <sup>3)</sup>                                       | <b>kg / lb</b>                 | 73,189 / 161,354 |
| Ground pressure, ISO16754 <sup>3)</sup>                              | <b>kg/cm<sup>2</sup> / psi</b> | 1.24 / 17.63     |

<sup>1)</sup> With fully retracted tilt / pitch cylinders, the mechanical pitch adjustment bolted in the rear position and including the grouser height, the lifting height is 1,863 mm (6'1").

<sup>2)</sup> With mechanical pitch adjustment bolted in the rear position and including the grouser height, the digging depth is 501 mm (19.7").

<sup>3)</sup> Including coolant and lubricants, 100% fuel, ROPS / FOPS cab, operator, Semi U-blade with 1-shank ripper.

# Rear attachments



## 1-Shank ripper

| Parallelogram                           |       | hydraulic pitch adjustment |              |
|---|-------|----------------------------|--------------|
|   |       | standard shank             | deep shank * |
| A Ripping depth (max. / min.)           | mm    | 1,445 / 705                | 1,895 / 705  |
|   | ft in | 4'9" / 2'4"                | 6'3" / 2'4"  |
| B Lifting height (max. / min.)          | mm    | 958 / 218                  | 959 / 364    |
|   | ft in | 3'2" / 9"                  | 3'2" / 1'2"  |
| C Additional length, attachment raised  | mm    | 1,949                      | 1,949        |
|   | ft in | 6'5"                       | 6'5"         |
| D Additional length, attachment lowered | mm    | 2,529                      | 2,529        |
|   | ft in | 8'4"                       | 8'4"         |
| E Overall beam width                    | mm    | 1,760                      | 1,760        |
|   | ft in | 5'9"                       | 5'9"         |
| Max. pitch adjustment                   |       | 30°                        | 30°          |
| Maximum penetration force               | kN    | 237                        | 237          |
|   | lbf   | 53,280                     | 53,280       |
| Max. pryout force                       | kN    | 441                        | 441          |
|   | lbf   | 99,141                     | 99,141       |
| Weight                                  | kg    | 7,194                      | 7,333        |
|   | lb    | 15,860                     | 16,166       |

\* Best performance to operate in loose material - deep shanks are designed for light and moderate duty.

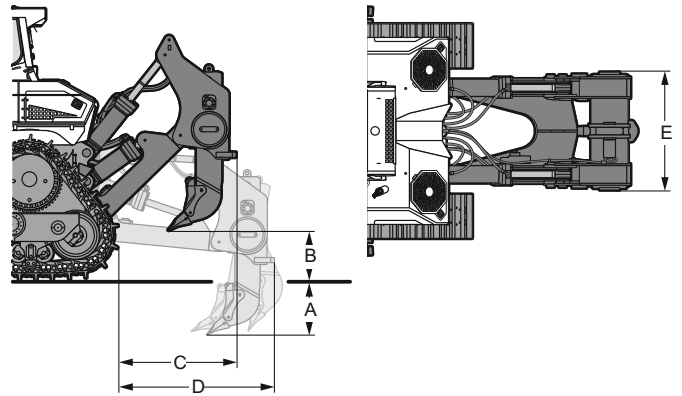

## 3-Shank ripper

| Parallelogram                           |       | hydraulic pitch adjustment |              |
|---|-------|----------------------------|--------------|
|   |       | standard shank             | deep shank * |
| A Ripping depth (max. / min.)           | mm    | 900 / 650                  | 1,896 / 706  |
|   | ft in | 2'11" / 2'2"               | 6'3" / 2'4"  |
| B Lifting height (max. / min.)          | mm    | 1,014 / 764                | 958 / 164    |
|   | ft in | 3'4" / 2'6"                | 3'2" / 6"    |
| C Additional length, attachment raised  | mm    | 1,904                      | 1,904        |
|   | ft in | 6'3"                       | 6'3"         |
| D Additional length, attachment lowered | mm    | 2,484                      | 2,484        |
|   | ft in | 8'2"                       | 8'2"         |
| E Overall beam width                    | mm    | 2,970                      | 2,970        |
|   | ft in | 9'9"                       | 9'9"         |
| F Distance between shanks               | mm    | 1,300                      | 1,300        |
|   | ft in | 4'3"                       | 4'3"         |
| Max. pitch adjustment                   |       | 30°                        | 30°          |
| Maximum penetration force               | kN    | 219                        | 219          |
|   | lbf   | 49,233                     | 49,233       |
| Max. pryout force                       | kN    | 441                        | 441          |
|   | lbf   | 99,141                     | 99,141       |
| Weight                                  | kg    | 9,430                      | 10,290       |
|   | lb    | 20,790                     | 22,686       |

\* Best performance to operate in loose material - deep shanks are designed for light and moderate duty.

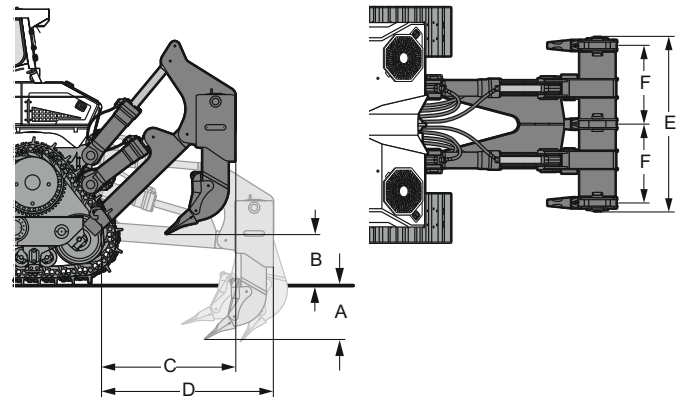

# Standard equipment



## Base machine

- Air filter, dry type, dual step with cyclones (pre-filter)
- Aluminium water and oil radiators wide-meshed
- Automatic dust ejector
- Battery compartment
- Cooling fan with safety guard
- Ecology drains (engine-, splitter box-, hydraulic oil)
- Engine compartment doors
- Fluid sampling ports (engine-, splitter box-, hydraulic oil)
- Fuel pre-filter, with electric heater and water separator
- Heavy duty steps and handles
- Hinged coolant radiator fan
- Hinged heavy duty belly pan
- Hinged hydraulic oil radiator fans
- Hinged radiator safety guard (water cooler)
- Hydraulically driven cooling fans
- LiDAT - Liebherr Data transmission system
- Liebherr diesel engine
- Thermal shields for turbo chargers
- Towing hitch (rear)
- Towing lug (front)
- Vandalism protection (7 padlocks)



## Hydraulics system

- Control blocks (two)
- Filters in replenishing circuits
- Float position blade
- Hydraulic kit for ripper
- Quick drop function blade
- Return filter in hydraulic tank
- Variable flow pump, load-sensing



## Travel drive

- Automatic parking brake
- Filters in leak oil return circuits
- Final drives planetary gear
- Hydrostatic travel drive
- Inch brake pedal
- Proportional travel drive joystick
- Travel speed ranges selection



## Electrical system

- Cold start batteries
- Emergency stop on the ripper
- Ground level service station (access light)
- Horn
- LED working lights
- Light engine compartment
- Lockable battery main switch



## Operator's cab

- Air-conditioning
- Armrests 3D adjustable
- Cab heating
- Coat hook
- Diagnostic connector
- Dome light
- Emergency stop switch
- Entry lights
- Footrest on the right side of the front console
- Longitudinally adjustable joysticks
- Operator awareness (seat contact switch)
- Operator's seat Comfort, air-suspended and heated
- Pressurised cab
- Radio preparation kit
- Rear mirror (inside)
- Rear view camera
- ROPS / FOPS integrated
- Safety switch
- Seat belt
- Socket 12 V
- Stowage compartment, air-conditioned
- Tinted safety glass
- Touch-controlled colour display
- Windshield washer system
- Windshield wipers front, rear, doors, with intermittent function



## Undercarriage

- Bolted sprocket segments
- Heavy duty track shoes (Super Extreme Service Shoes)
- Hydraulic track adjuster
- Oil-lubricated PPR tracks
- Rollers and idlers, lifetime lubricated
- Track guide
- Two-piece master link
- Undercarriage with oscillating idlers and rollers (bogie suspension)



## Front attachments

- Rock guard with overflow panel on Semi U-blade
- Rock guard with overflow panel on U-blade



## Inspection warning lights

- Air filter contamination
- Battery charge
- Date and time
- Diesel engine
- Diesel engine preheating
- Diesel engine speed
- ECO-Mode
- Engine coolant temperature
- Float position blade
- Fuel level
- Fuel water separator
- Hour meter
- Hydraulic oil return filter contamination
- Hydraulic oil temperature
- Parking brake
- Pump replenishing pressure
- Travel drive oil temperature
- Travel speed ranges

Standard equipment may vary. Consult your Liebherr dealer for details.

# Optional equipment



## Base machine

- Working platforms with handrail
- Extended tool kit
- Fuel pre-filter, with electric heater and water separator (metal bowl)
- GPS Grade control ready kit1)
- Handrail without working platforms
- Hour meter in engine compartment
- Maritime transport packaging
- Powered access ladder
- Automatic centralized lubrication system
- Quick change for engine, hydraulic and splitter box oil
- Ground level quick refueling
- Reversible cooling fan
- Special colour scheme
- Thermal isolation for engine turbo charger and exhaust gas pipes



## Travel drive

- Detented travel drive joystick



## Operator's cab

- Fire extinguisher in the cab
- Operator's seat Premium, air-suspended, heated and ventilated
- Operator's seat Premium with 3-point belt system
- Radio
- Rear mirror left and right on cab, outside
- Sliding window left
- Sliding window rear
- Sliding window right
- Sunblind, all around



## Electrical system

- Amber beacon
- Back-up alarm
- Back-up alarm (acoustic and visual, switchable)
- Back-up alarm (switchable)
- Emergency stops on engine hood (left and right)
- "High Density" (4,200 lm) LED working lights
- Jump start plug 24 V
- Lockable starter isolator switch
- One (1) additional LED working light on the ripper
- Two (2) additional LED working lights on the rear of the cab



## Undercarriage

- Carrier rollers
- Sprocket segments with recesses
- 710 mm (28") track shoes
- 762 mm (30") track shoes
- Track shoes with mud holes



## Front attachments

- Hydraulic pitch adjustment (dual tilt)
- Protection for blade pitch cylinder
- Protection for blade tilt cylinder
- Push plate for Semi U-blade
- Wear plates on push frame (580 kg / 1,279 lb)
- Wear plates on Semi U-blade (920 kg / 2,028 lb)
- Wear plates on U-blade (680 kg / 1,499 lb)
- 18.5 m<sup>2</sup> Semi U-blade
- 22.0 m<sup>2</sup> U-blade
- 46.0 m<sup>2</sup> Coal U-blade



## Rear attachments

- 1-Shank Ripper (standard or deep shank)
- 3-Shank Ripper (standard or deep shank)
- Counterweight (7,000 kg / 15,432 lb)
- Hydraulic pin puller for 1-shank ripper



## Control and warning lights

- Auto Idle
- Automatic engine shut-down
- Coolant level
- Engine after run
- Hydraulic oil level
- Preparation tilt switch 35 degrees
- Reversible fan



## Specific solutions

- Arctic package (-30 °C / -22 °F, -40 °C / -40 °F)
- Coal stockpiling equipment package
- High altitude package > 2500 m

# The Liebherr Group



## Global and independent: more than 70 years of success

Liebherr was founded in 1949. With the development of the world's first mobile tower crane, Hans Liebherr laid the foundations of a successful family business which today comprises more than 140 companies on all continent and employs nearly 51,000 people. The parent company of the Group is Liebherr-International AG in Bulle (Switzerland), whose associates are exclusively members of the Liebherr family.

## Technology leadership and pioneering spirit

Liebherr regards itself as a pioneer. This spirit has enabled the company to make a decisive contribution to the technological history of many industries. Today, employees around the world still share the courage of the company founder to take new paths. They are all united by a passion for technology and fascinating products and the determination to perform outstanding work for their customers.

## Widely diversified product portfolio

Not only is Liebherr one of the biggest construction equipment manufacturers in the world, it also provides high-quality, user-oriented products and services in a wide range of other areas. The product portfolio includes the segments earthmoving, material handling technology, deep foundation machines, mining, mobile and crawler cranes, tower cranes, concrete technology, maritime cranes, aerospace and transportation systems, gear technology and automation systems, refrigeration and freezing, components and hotels.

## Customized solutions and maximum customer benefit

Liebherr solutions are characterized by maximum precision, outstanding implementation and exceptional longevity. Its mastery of key technologies enables the company to offer its customers customized solutions. For Liebherr, customer focus does not end with the product; it also encompasses a wide range of services that make a real difference.

[www.liebherr.us](http://www.liebherr.us)

## WARNING

Breathing diesel engine exhaust exposes you to chemicals known to the State of California to cause cancer and birth defects or other reproductive harm.

- Always start and operate the engine in a well-ventilated area.
- If in an enclosed area, vent the exhaust to the outside.
- Do not modify or tamper with exhaust system.
- Do not idle the engine except as necessary.

For more information go to [www.P65warnings.ca.gov/diesel](http://www.P65warnings.ca.gov/diesel).

## WARNING

This product can expose you to chemicals including lead and lead compounds, which are known to the State of California to cause cancer and birth defects or other reproductive harm.

For more information go to [www.P65warnings.ca.gov](http://www.P65warnings.ca.gov).

## Liebherr-Werk Telfs GmbH

Hans-Liebherr-Straße 35 • 6410 Telfs, Austria • Phone +43 50809 6-100 • Fax +43 50809 6-7772  
[lwt.marketing@liebherr.com](http://lwt.marketing@liebherr.com) • [www.liebherr.com](http://www.liebherr.com) • [www.facebook.com/LiebherrConstruction](http://www.facebook.com/LiebherrConstruction)