

XF Series

XF6300 | XF8500

HYUNDAI WIA 5-Axis Vertical Machining Center

THE WORLD BEST

When it comes to 5-axis machine tool technology, people tend to consider a product made in Japan, Germany and Switzerland to be the best.

In the past this may have been true, that is up until now.

Introducing the XF series. The Best 5-axis Vertical Machining Center in the World.



TECH CUBE, HYUNDAI WIA Europe Technical Center

In our determination to develop machine tools that deliver unrivalled satisfaction to our customers, and our unwavering commitment to grow into the world's best machine tool company, HYUNDAI WIA have established a technical support center in Germany.

Through its new European Technical Center, HYUNDAI WIA will not only enhance technical support for its European clients but also run a variety of marketing campaigns on the continent with the aim of growing into the leading machine tool brand in the entire European market.

Notably, the company will staff the R&D Center with world-class researchers who will take the lead in promoting the technological enhancement by developing new machine tools that far surpass the performance of existing machine tools in Europe.

HYUNDAI WIA is now set to become a global player.

Cutting Edge Technology

The XF series 5-axis vertical machining center in the world-best level, developed by HYUNDAI WIA Europe R&D Center. **XF series** are a perfect blend of machine and technology to realize the ultimate performance in composite machining and mold machining with the highest quality possible resultant of its cutting-edge design features such as the monoblock type bed structure, X/Z axis box-in-box structure, etc.

XF SERIES

ITEM		XF6300	XF8500
Table size	mm(in)	Ø630 (Ø24.8")	Ø850 (Ø33.5")
Max. load capacity	kg (lb)	600 (1,323)	1,000 (2,205)
Spindle speed	rpm	15,000 [24,000/40,000]	15,000 [9,000/24,000/30,000]
Spindle power (Max/Cont.)	kW (HP)	31/25 (41.6/33.5) [26/20 (35/27)] [26/18 (35/24)]	31/25 (41.6/33.5) [42/31 (56.3/41.6)] [26/20 (35/27)] [120/80 (160.9/107.3)]
No. of tools	ea	34 [68, 102]	
Travel (X/Y/Z)	mm(in)	650/765/500 (25.6"/30.1"/19.7")	850/920/600 (33.5"/36.2"/23.6")
Rapid traverse rate (X/Y/Z)	m/min (ipm)	60/60/60 (2,362/2,362/2,362)	45/45/45 (1,772/1,772/1,772)



XF6300

XF8500



THE INNOVATION

People ask: "How could machine tool be so innovative?"

The appearance of HYUNDAI WIA's XF series may look like an ordinary machine tool. However, XF series are designed with a high-tech monoblock type bed structure, box-in-box type structure and other advanced features to differentiate it from standard machine tools.

High accuracy and productivity are achieved through its innovative structure.



**EXPERIENCE
THE NEW TECHNOLOGY**

04
+
05

XF Series
5-axis Vertical Machining Center



Applications & Parts

VACUUM PUMP
ROTOR



IMPELLER



HOUSING,
GEAR BOX



HOUSING,
GEAR BOX



HOUSING,
ELECTRIC MOTOR



BLADE,
COMPRESSOR



HOUSING,
ENGINE



TIRE MOLD



XF SERIES

Cutting Edge Technology

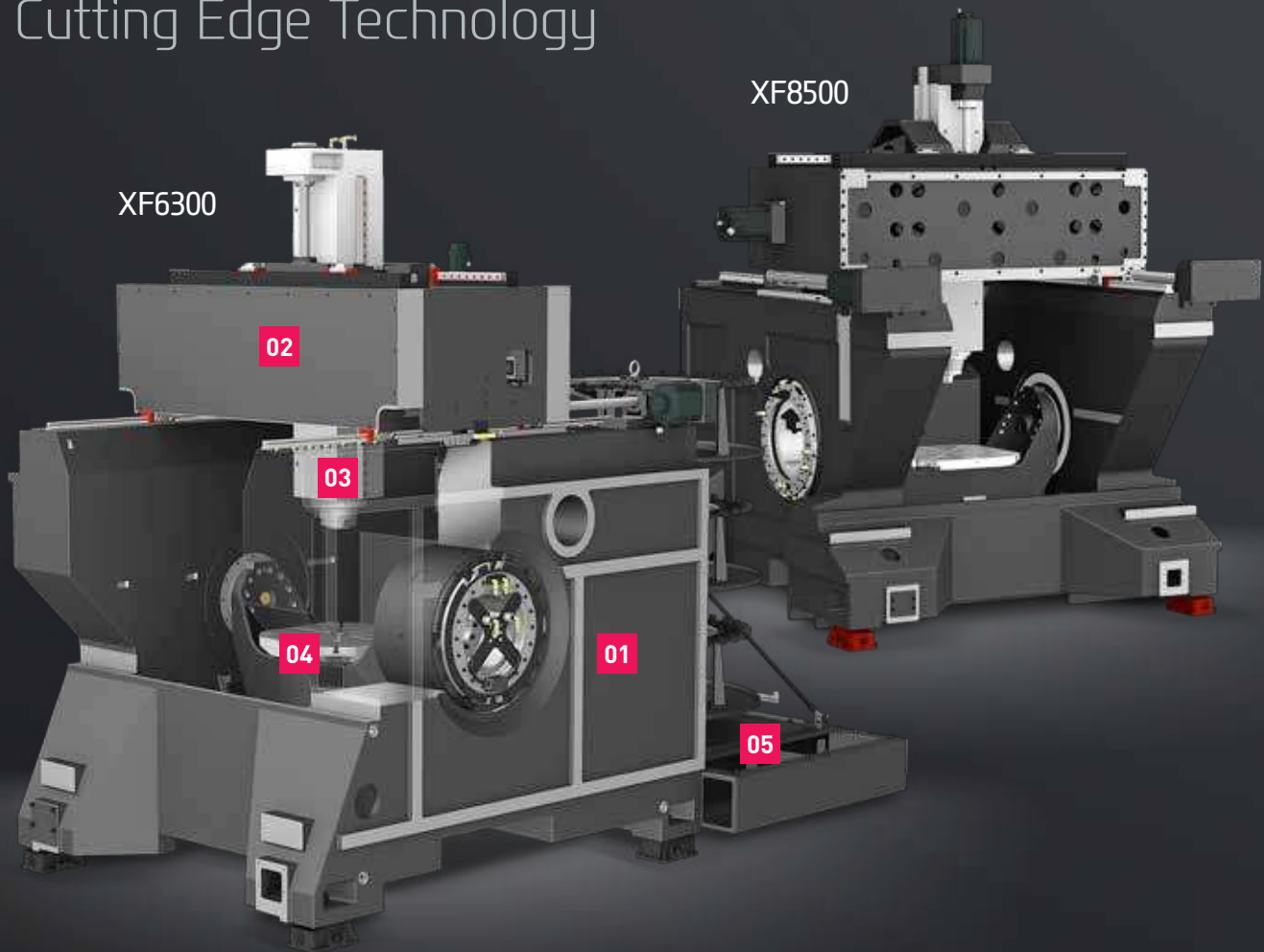

XF6300

❖ HEIDENHAIN TNC640 Rapid traverse rate (X/Y/Z) : 50/50/50 m/min (1,967/1,967/1,967 ipm)

60/60/60 m/min (2,362/2,362/2,362 ipm)
Rapid traverse rate (X/Y/Z-axis)

70/110 r/min
Rapid traverse rate (A/C-axis)

650/765/500 mm (25.6"/30.1"/19.7")
Travel (X/Y/Z-axis)

150/360 deg
Travel (A/C-axis)

XF8500

45/45/45 m/min (1,772/1,772/1,772 ipm)
Rapid traverse rate (X/Y/Z-axis)

50/100 r/min
Rapid traverse rate (A/C-axis)

850/920/600 mm (33.4"/36.2"/23.6")
Travel (X/Y/Z-axis)

150/360 deg
Travel (A/C-axis)

Basic Features

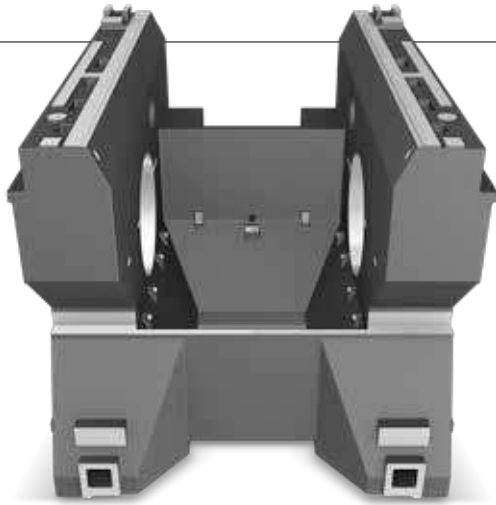

01

Column/Bed All-in-One Structure

XF series are designed with an integrated one piece column-bed structure provides superior stability when compared with separate structures.

The All-in-One structure delivers high rigidity and excellent vibration absorption providing exceptional performance and superior surface finishes.

<Monoblock Structure>

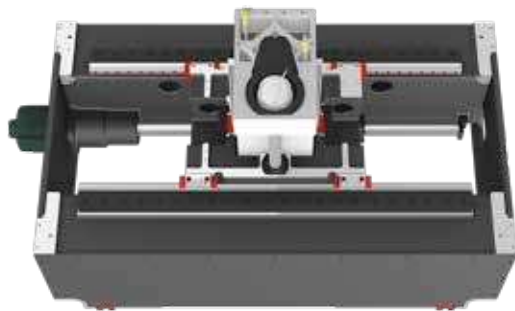

02

Box-in-Box Structure (X/Z Axis)

The pusher(head body) in the saddle of X-axis, which surrounds the spindle cartridge, is designed with box-in-box type. This thermal equilibrium structure helps minimize thermal deformation.

Built-In Spindle

03

The built-in spindle minimizes spindle vibration, enabling outstanding performance in a high-precision cutting environment such as mold products.



DDM Tilting Rotary Table

04

The DDM rotary table is designed to embody highly accurate high speed simultaneous 5-axis motion which allows for the machining of complex prismatic parts with superior accuracy and surface finishes.



Rack Type Magazine

05

A single step Rack type magazine of 34 tools is provided as a standard. 2 step 68 tools and 3 step 102 tools featured as an option.

XF630 :
Rack Type ATC

XF8500 :
Pickup Type ATC [Twin Arm]



01
XF Series

Body Structure

High-Precision & Speed 5-Axis Vertical Machining Center



The strength and rigidity of the base body structure is a direct link to the precision of a machine tool.

HYUNDAI WIA's advanced body design coupled with an integrated bed/column structure is the foundation of machining perfection.

The advantages of HYUNDAI WIA's body design is not limited only to extreme cutting speeds.

The integrated body remarkably reduces the minute vibration during machining ensuring high precision and superior surface finishes. The HYUNDAI WIA XF series will exceed all of your expectations.

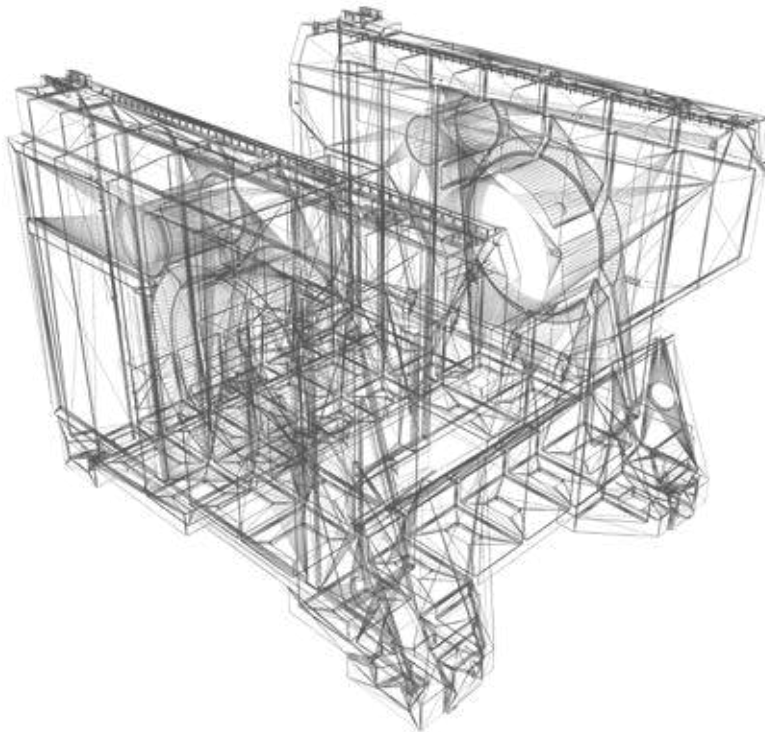

Optimal Structural Analysis (FEM)

The XF series are designed to be the optimum structure through HYUNDAI WIA's exclusive structural analysis.

Column / Bed All-in-One Structure (Rigidity has improved by 130%)

The XF series are designed with an integrated one piece column-bed structure providing superior stability when compared with separate structures. The All-in-One structure delivers high rigidity and excellent vibration absorption providing exceptional performance and superior surface finishes.

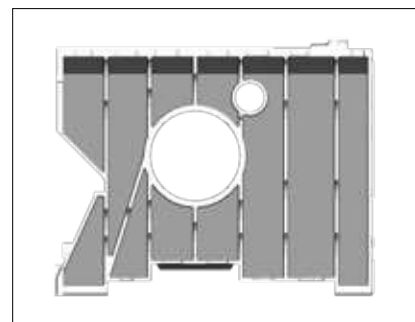
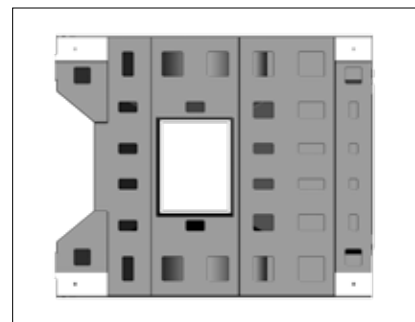
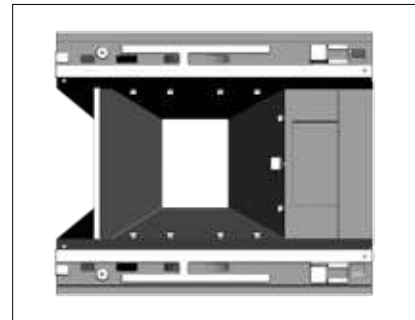

- > The monoblock design and integrated bed/column structure provides high rigidity ensuring outstanding dynamic characteristics
- > Highly rigid structure without holes on the side wall and a minimal number holes are required on the top and bottom top area
- > Casting rib structure optimized for high rigidity
- > The integrated rotary table A-axis/column structure ensures high rigidity and superior precision
- > The bed structure's agronomical design allows for easy access to the work area

02

XF Series

Slideway Features

High-Precision & Speed 5-Axis Vertical Machining Center

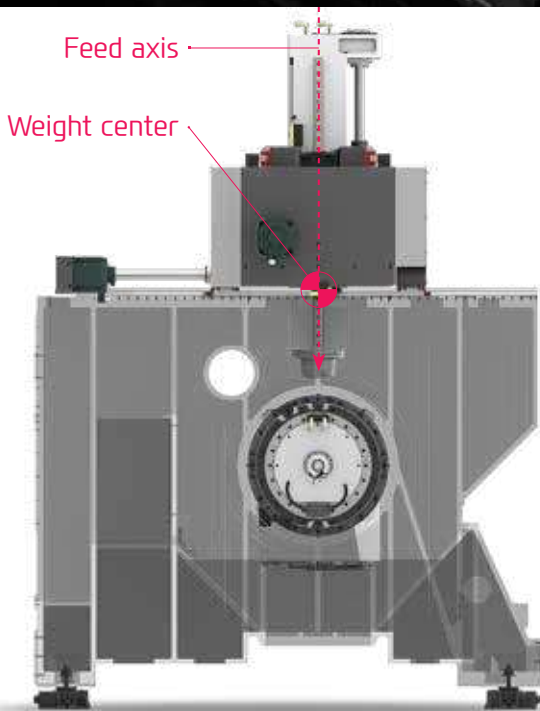
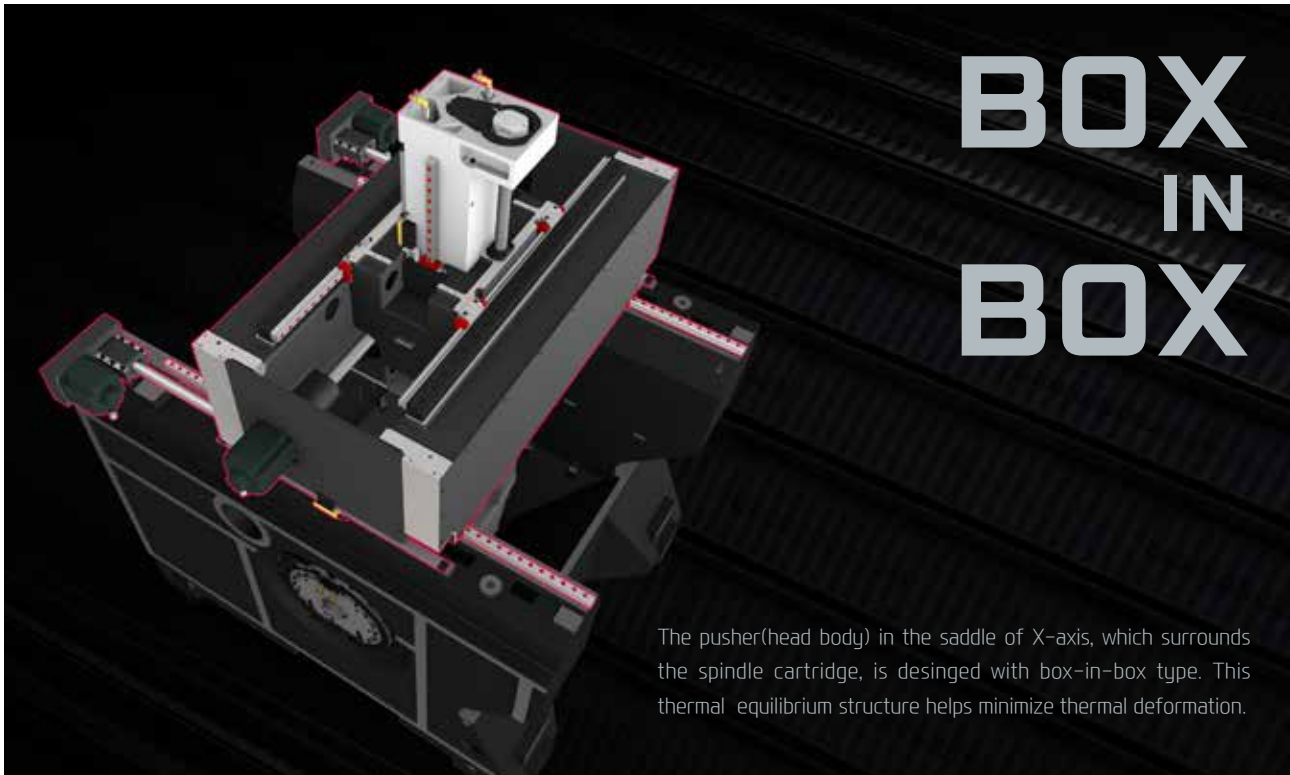

Symmetric Structure of Z-axis

Vibration and thermal displacement during travel can be minimized by symmetric structure of Z-axis where travel axis is aligned with the weight center of spindle.

Y-axis Double Ballscrew Structure

The Y-axis is driven by two ball screws and feed motors to provide unprecedented speed, accuracy, stability, and acceleration than general purpose machines.

XF6300

650/765/500 mm (25.6"/30.1"/19.7")
Travel (X/Y/Z)

XF8500

850/920/600 mm (33.4"/36.2"/23.6")
Travel (X/Y/Z)

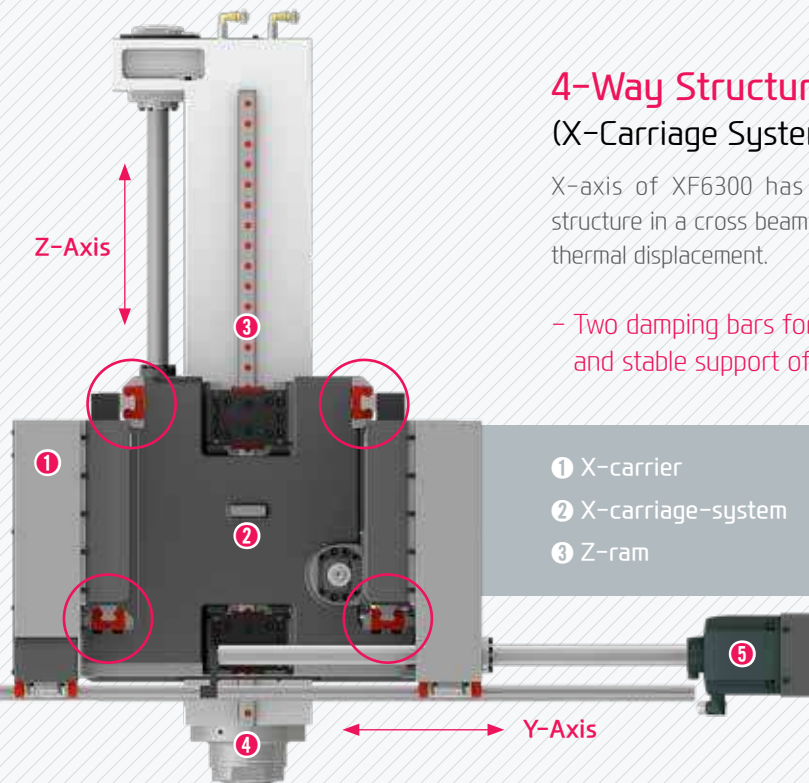

4-Way Structure on X Axis (X-Carriage System)

X-axis of XF6300 has box-type saddle design with 4-way structure in a cross beam to realize improved strength and minimal thermal displacement.

- Two damping bars for the X and Z axis slide providing rigid and stable support of the ram

- | | |
|---------------------|-------------------------------|
| ① X-carrier | ④ Spindle |
| ② X-carriage-system | ⑤ Drive for Y-carriage-system |
| ③ Z-ram | |



High-Speed Roller LM Guideway

The XF series features roller type LM guideway to reduce non-cut time with faster acceleration while providing high rigidity.

● Feed Axis Acceleration/Deceleration (X/Y/Z axis)

XF6300 - 1.0G/0.8G/1.0G XF8500 - 0.75G/0.75G/0.75G

❖ Acceleration/deceleration is slightly different when you choose HEIDENHAIN PLC.



High-Precision Linear Scale (Standard)

The XF series are equipped with linear scales on all axes providing high precision positioning accuracy and compensates for ball screw thermal displacement ensuring extremely precise machining.

In addition, the absolute type linear scale is installed in close proximity to the ball screw of each axis. During operation an added benefit is not being require to home the machine.

n3
XF Series

Built-in Spindle

Long Lasting High Accuracy & Excellent Performance
5-Axis Vertical Machining Center



Built-in Spindle

Built-in Spindle

The built-in spindle minimizes spindle vibration, enabling outstanding performance in a high-precision cutting environment such as mold products.

Spindle Cooling

Spindle temperature is controlled by the use of a spindle oil chiller. This ensures consistent spindle temperature which minimizes thermal displacement.



HSK Tool Holder

HSK tool holder is utilized for precise positioning with less expansion in the spindle taper during high speed rotation. This ensures an excellent level of precision for die mold machining.

Through Spindle Coolant {20/30/70 bar (290/435/1,015 psi)} **OPTION**

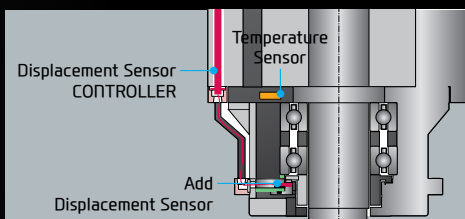

Spindle Heat Displacement Sensor

By attaching a hardware heat displacement sensor to the spindle cartridge, the amount of thermal displacement generated during machining is directly recognized and corrected by the displacement amount.

Heat Displacement Sensor Calibration + Displacement Sensor Calibration

Spindle

ITEM	Speed r/min	Power (Max./Cont.) kW (HP)	Torque (Max./Cont.) N·m (lbf·ft)	Tool Holder
XF8500	9,000	42/31 (56.3/41.6)	175/130 (129/95.9)	HSK-A63
XF6300 XF8500	15,000	31/25 (41.6/33.5)	153/123 (112.8/91)	HSK-A63
XF6300 XF8500	24,000	26/20 (35/27)	85.9/66.5 (63.4/49)	HSK-A63
XF8500	30,000	120/80 (160.9/107.3)	38.2/25.5 (28.2/18.8)	HSK-E40
XF6300	40,000	26/18 (35/24)	9.9/6.9 (7.3/5)	HSK-E40

04

XF Series

Tilting Rotary Table

Super Quality & Productivity
5 Axis Vertical Machining Center



Column-Integrated Table

The A-axis table is designed to be integral to the column. To do so the table is secured using HYUNDAI WIA's proprietary method of injecting a specially formulated epoxy resin into a gap between column and table.

This assembly technic delivers excellent clamping force and shock absorption are provided from the column.

XF6300

Ø630 mm (Ø24.8")
Table size

Max. 600 kg (1,323 lb)
Max. load capacity

XF8500

Ø850 mm (Ø33.4")
Table size

Max. 1,000 kg (2,205 lb)
Max. load capacity

Tilting Rotary Table



DDM Tilting Rotary Table

The XF series has a **tilting rotary table** is designed to embody highly accurate high speed simultaneous 5-axis motion which allows for the machining of complex prismatic parts with superior accuracy and surface finishes.

The direct drive system utilizes **direct drive motor (DDM)** delivering high precision and high speed for improved productivity. The integrated A-axis housing/column design ensures high rigidity.

❖ The XF series may cause some interference in the machining area.
Please check the interference area chart on page 36 of the catalog.

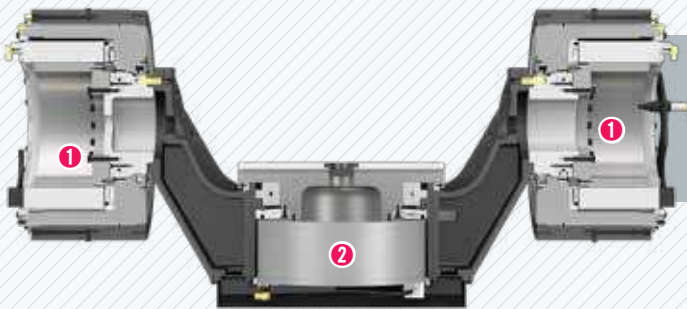
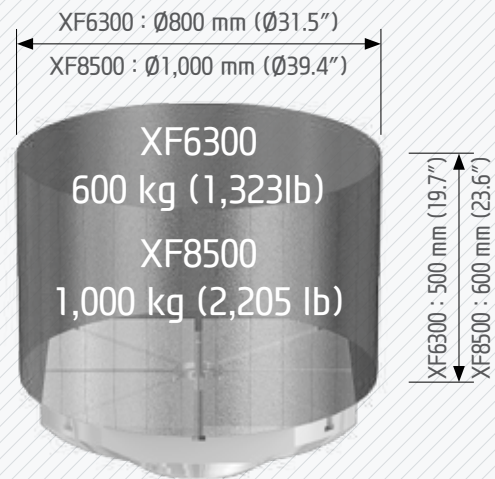

DDM TABLE (Simultaneous 5-Axis)

- ① A-axis built-in motor (tandem type)
- ② C-axis built-in motor

- ⊙ A/C indexing angle : **+30°~-120°/360°**
- ⊙ XF6300 A/C indexing speed : **70/110 rpm**
- ⊙ XF8500 A/C indexing speed : **50/100 rpm**



A/C-Axis Rotary Scales Standard

Scale integrated YRTM bearing is assembled directly to the C-axis rotary table providing high precision positioning accuracy and repeatability

- ⊙ **A-axis : Rotary Scales** (5 sec. precision)
- ⊙ **C-axis : YRTM Bearing** (Scale embedded bearing)

05

XF Series

ATC & Magazine

High-Precision & Speed 5-Axis Vertical Machining Center



ATC & Tool Magazine

Tool change time (chip-to-chip) of 4.5 seconds is the best in its class. The rack type tool change mechanism was developed to add unprecedented extra-large capacity tool for vastly complex 5 axis machining applications.

A single step rack magazine of 34 tools is provided standard. 68 and 102 tool capacity are optional.

<XF8500 : Multi Step Rack Type Magazine & TWIN ARM ATC - Option>

Rack Type Magazine

34 [68, 102] ea
No. of tools

4.5 sec
Tool change time (C-C)

❖ C-C : XF6300 - 3kg (6.6lb) tool base

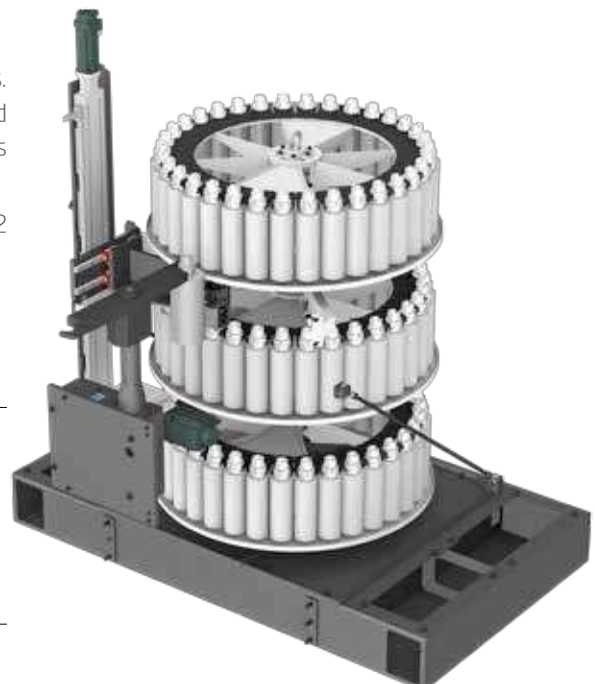

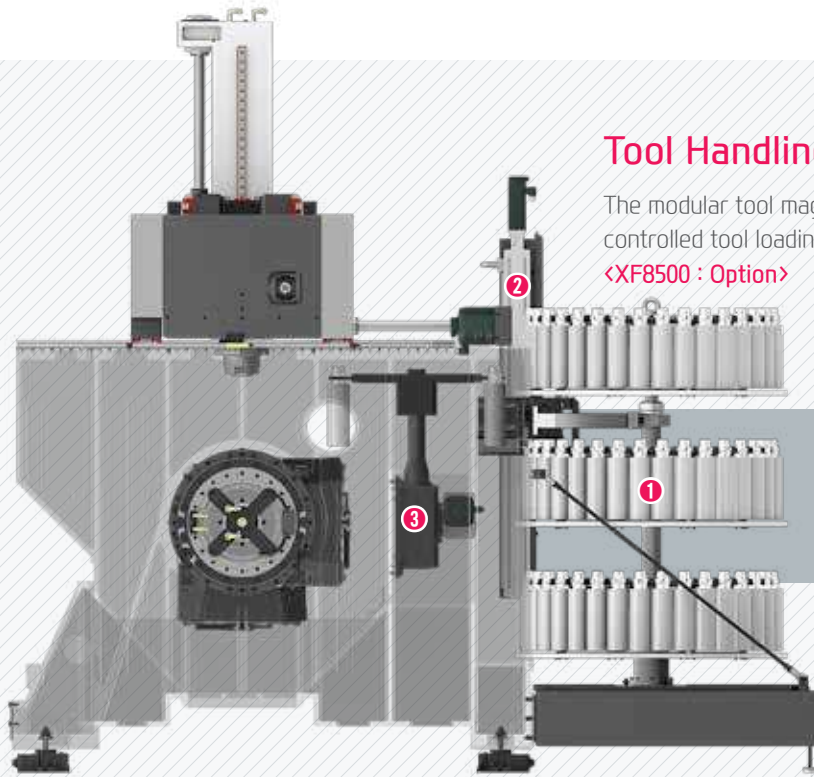

Tool Handling System (2-Axis Loading)

The modular tool magazine of XF6300 is designed as a 2-axis controlled tool loading system for quick tool change.

<XF8500 : Option>

- ① Rack Type Tool Magazine
- ② Tool Handling System
- ③ ATC (Twin Arm)

Magazine

The tool magazine and machining area are completely separated by a shutter door to prevent coolant and chip contamination out of the tool storage area maintaining high precision and cleanliness. Minimal tool change distance between the tool changer and work area permits for a rapid tool change.

In addition, collision is avoided regardless of A-axis position eliminating the need for homing of A-axis.

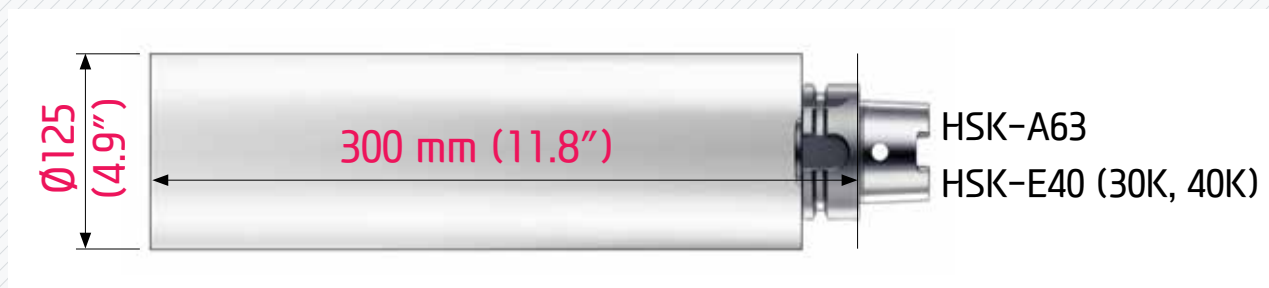

- ⊙ Max. Tool Dia. (W/T Adjacent Tool) : $\varnothing 90/\varnothing 125$ ($\varnothing 3.5"/\varnothing 4.9"$)
- ⊙ Max. Tool Length : 300 mm (11.8")
- ⊙ Max. Tool Weight : 8 kg (17.6 lb) [40K : 1.5 kg (3.3 lb)]



FAST & DYNAMICS & CONVENIENCE

- Highest level of acceleration and deceleration (FAST): Acc./Dec. time-1G
- High performance built-in 15,000 rpm spindle (DYNAMIC) supplying 153 N·m (113 lbf·ft) of torque : Breaking the mold regarding high speed spindle and high torque
- The 19" monitor allows for easy viewing and accessibility through its ergonomic design (CONVENIENCE)

Those are just some of the values that the XF series pursues.



n6
XF Series

SIEMENS Controller

The Powerful CNC Platform for Machine Tools



SIEMENS

**DIFFERENTIATED CAPABILITIES,
INTEGRATED ENGINEERING SEAMLESSLY INTERLINKED**

SIEMENS 840D sl is the latest generation CNC controller with the capability of running up to 20 axes on a single machine.

The powerful 80-bit controller reduces processing time and increases productivity. It supports the preparation of a variety of programs and setup functions for ease of operation.

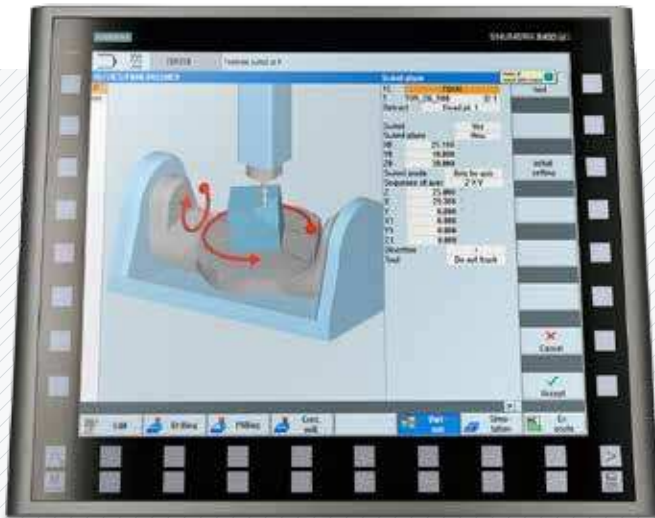

SIEMENS Technology

Shop Mill

- Dialogue-type programming, simple and convenient
- Effective specifications for small quantity batch production
- Step-by-step operation possible without knowledge of the DIN/ISO code



Real Time 3D Simulation

- Real time 3D simulation is possible
- 2D simulation offered standard
- Possible to confirm NC program thru simulation

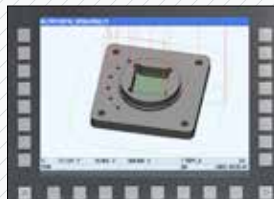

Easy Screen

- Create an easy screen
- Insert text and pictures
- Max. 5-screen configuration
- PLC variables and PLC interface with read/write support



SIEMENS MDrive



SIEMENS MDrive is required for a variety of CNC mold processing software solutions which is combined into one package achieving the highest processing rates

ISO Code Programming



If the ISO Dialect (G291) is ordered, JIS-based G-code programs can be used. (Standard)

07
XF Series

HYUNDAI-iTROL⁺

The Powerful CNC platform for Machine Tools



Simple & Modern Identity

19" Multi-Touch Screen

DESIGN

Add value to Modern Premium!

Combination of machine tool, IT technology and networking!
HYUNDAI WIA opens new era of Smart Machine with
HYUNDAI-iTROL⁺

PINUP Design Award Awarded

Ergonomic Design

Robust and High Quality Aluminum Frame

HYUNDAI - iTROL⁺ HYUNDAI Intelligent Control

HYUNDAI-iTROL⁺ & SIEMENS Motor & Drive provide the best solution!



Tilting Angle

30°

- 01** 19 inch Multi-touch Monitor
- 02** Convenience enhanced White Grip
- 03** Quick Function Bar
- 04** Keyboard/MCP Integrated Panel that enables 30° folding (Keypad LED Lighting)



HYUNDAI-iTROL⁺ Smart Function

Smart Factory



It is able to check machining list and its status using Regular Maintenance App. Also, you can improve the work by analyzing the problems occurred in the past.

- Check regular inspection and past work history
- Check Work Order/Machining Criteria/Shape of Object/Tool List before machining
- Check machining load, change of transfer speed, status of other equipment during operation

Smart Programming



This cloud-based programming automation system enables programming by inputting a 3D model, one-touch shape analysis, and NC program creation.

- Model file input / 3D modeling function (NX, STEP, IGES, DWG, DXF, etc.)
- One-touch automatic creation of 5-face part machining programs
- 3D simulated machining / forecasting of machining time

Smart Operation



Collision simulation based on a virtual machine can prevent collision caused by worker negligence in the manual mode.

- 3D machining monitoring through the virtual machine and machining function
- Collision prevention function in the manual operation mode
- Enhanced tool and workpiece setting for user convenience

Smart Machining



Tool monitoring (TM), machining speed adaptive control (AFC) features are equipped as default to improve convenience, and machining accuracy is improved by balance measurement of workpiece.

- Equipped with Tool Monitoring (TM) and machining speed adaptive control (AFC) features as default.
- Shifted load compensation feature through balance measurement of workpiece

Smart Diagnosis



Automatic recovery is available through 1 time click of ATC recovery button. It is able to use it to analyze machine's defective status through data collection function for electronic manual and equipment diagnose.

- Reinforced ATC Recovery Function
- Electronic manual is equipped for convenient search and accessibility
- Collect main data for equipment diagnose

Smart Network Service



Smart Network Services, that can monitor the operating status of machining tools in the factory, can perform documentations and CAC /CA M through remote access to user PC.

- Monitor the status of factory operation
- Remote access to other equipment and office PCs

n8

XF Series

HEIDENHAIN

TNC Contouring Control with Drive System

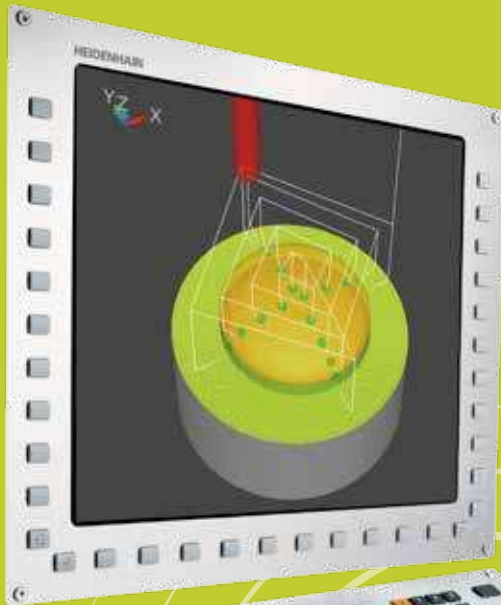

HEIDENHAIN

The TNC 640 is compact and easy to read.

The TNC 640 is a versatile contouring control system that can control a 19-inch screen and up to 18 axes.

Its flexible workshop-friendly programming functions, Heidenhain interactive programming and offline programming, allow the user to create the optimal machining environment.

dynamic + **precision**



Portable Handwheel >>



Perfect 5-Axis Machining

- Powerful motion control shows its strength in 5-axis machining
- ADP (Advanced Dynamic Prediction) for high surface quality and contour accuracy
- Interpolation turning / hobbing of external gears

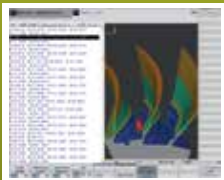

Detailed Simulation

- PDF files, drawings, etc. can be opened directly on the control
- high resolution, finely detailed 3D simulation function
- 0.5ms block processing time / 21G of storage
- Calculates the geometry ahead of time in order to adjust the feed rate (5,000 blocks).

HW-MCG (Machine Guidance)

PC S/W for various user conveniences such as machine control, maintenance, monitoring and etc.

Common Function

M-code List | Operation Status | Work Count | Working ratio |
 I/O Monitor | Cycle Time Monitoring | Working Time |
 Machine Option List | Macro Guide |



M-code List
 M code search & guide function

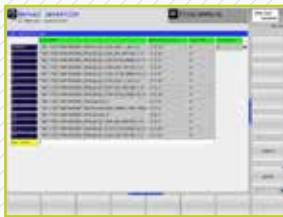

Operation Status
 Program history
 managing function



Work Count
 Managing work count & lifespan

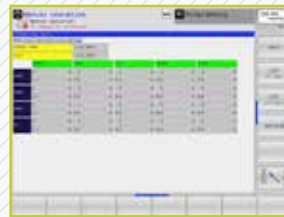

Working ratio
 Power/Running/Machining/
 Spindle/Alarm Time

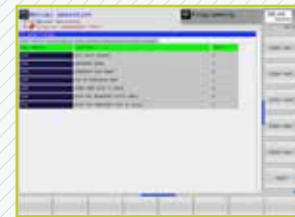

I/O Monitor
 Sensor & sol. valve status
 monitoring



Working Time
 Particular program block
 analysis

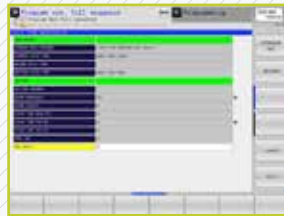

Cycle Time Monitoring
 Alarm function according to C/T



Macro Guide
 Macro manual for
 Hyundai WIA S/W



Machine Option List
 Machine option list searching &
 setting



HW-TDC
 HYUNDAI WIA Thermal
 Displacement Compensation

- Thermal displacement compensation designed to minimize machining deviations caused by changes in the external.
- Overcooling control when the main spindle stops.
- Direct compensation by the displacement sensor.
- Same HMI structure as FANUC/SIEMENS for operational convenience.



HW-WARMUP
 HYUNDAI WIA
 Tool Monitoring

- Main spindle stop time check → automatic setting of warm-up time.
- Interlock disables the machining cycle if warm-up is not performed.
- Customer machining program in the warm-up auto mode.
- Automatic warm-up logic when the cycle start begins.
- Same HMI structure as FANUC/SIEMENS for operational convenience.

n9

XF Series

Mold Package

Powerful Mold Package, HYUNDAI-WIA Die Mold All in One



HYUNDAI-WIA Mold Package

The XF series are equipped with the HW mold package for efficient mold machining.

The die mold package includes MDynamics, the most advanced mold software prepared by SIEMENS. Spindle thermal displacement compensation, and automatic tool measuring system ensure high quality mold machining.

SIEMENS 840D sl

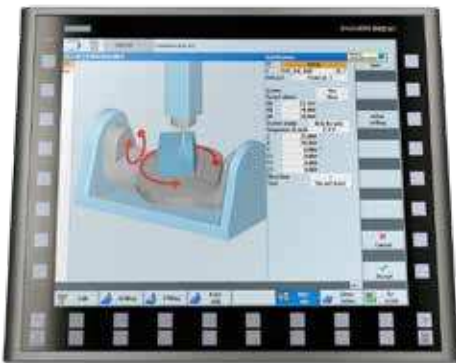

- 1 MDynamics
(High speed/High accuracy function)
- 2 Automatic Power Off Device
- 3 PCU50.5 (Hard Disk Included)



4 Main Spindle Cooling Device (8-channel)

Spindle temperature monitored with embedded thermal sensors



5 Cutting Air Blow

Mold machining without coolant



6 Auto Tool Measuring Device Renishaw (nc4) BLUM (Laser Control Micro Compact)

Sets tool length and detects wear

SIEMENS MDynamics 5-Axis Package

- Shop mill
- Remaining material sensing
- Real-time 3D simulation
- Spline interpolation
- 5-axis processing package
- 3D tool radius compensation
- 1,000 block look ahead
- Advanced surface
- Transmitting and circumferential shift
- Measurement cycles
- Compact Flash Card ready
- Coordinate measurement system



Advanced Surface

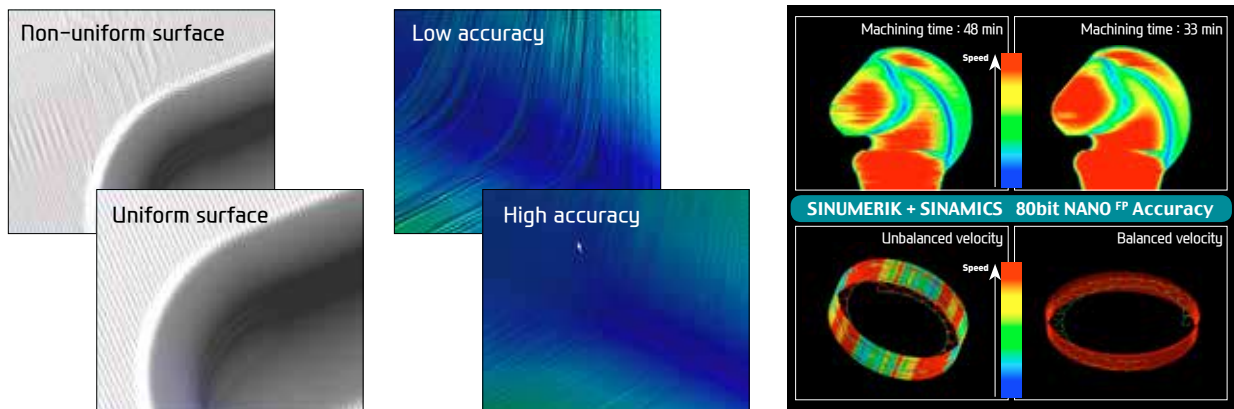

- Advanced surface software for high speed, high accuracy mold processing
- 80-bit floating-point calculation accuracy is superior to nano-interpolation
- A brand new filter for speed and acceleration control - Minimizes errors generated from irregular CAM data
- Standard jerk-restriction function to ease deceleration impact - Minimized vibration and high-speed deceleration
- Standard feed-forward function for speed control - Improves contouring accuracy by correcting the following error before setting point output

10

XF Series

User Convenience

Various Devices for User Friendly



Large 19" Monitor

The XF series adopts a 19" monitor for improved visibility of SIEMENS's main NC functions including shop mill and 3D simulation.

19 inch Monitor size **120 deg** Indexing angle

1,450 mm (57") Height From the screen center

Ergonomic Operation Panel

The XF series are designed to be 1,450mm (57") high for ease of operation while setting up and running a workpiece.

In addition, the PC keyboard ensures user convenience.

120° (±60°)

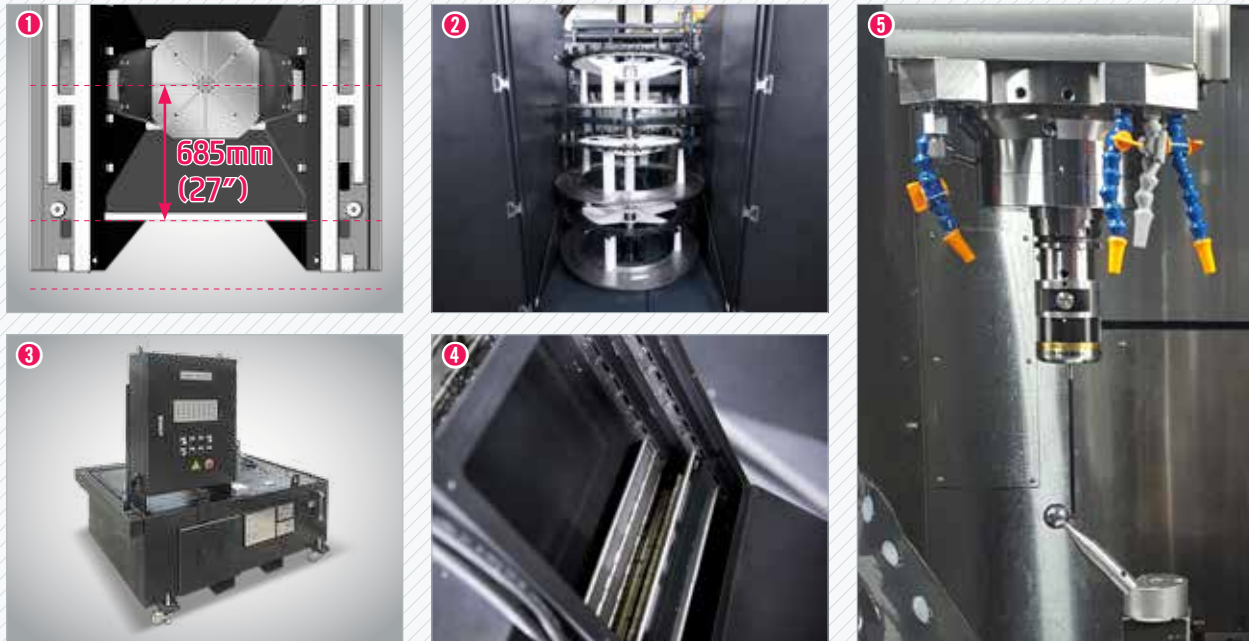

1 Improved Accessibility to Table

The short distance (XF6300 : 685mm [27"], XF8500 : 676mm [26.6"]) between the front of bed and the center of table facilitates easy workpiece and fixture setup.

2 Convenient Tool Change

The magazine cabinet located at the rear of the machine simplifies tool change.

3 Separate Coolant Tank

A coolant tank holding up to 1,200 l [317 gal] (optimal capacity: 800 l [211 gal]) is provided.

The coolant tank is a separated from the heat source not allowing heat to be transferred to the machine, resulting in precision improvement.

4 Wedge Wire Chip Conveyor (Integrated **Scraper** and **Hinge** Type)

A combined structure of a scraper type chip conveyor and hinge type rail allows general chips and fine chips to be disposed of at all times.

5 Auto Pivot Compensation

It can be easily self-calibrate the A-axis and C-axis displacement due to processing conditions and surroundings are always able to maintain a high accuracy.

<Pivot Compensation software (HW-TPC) : Std. Probe & Datumball : Opt.>

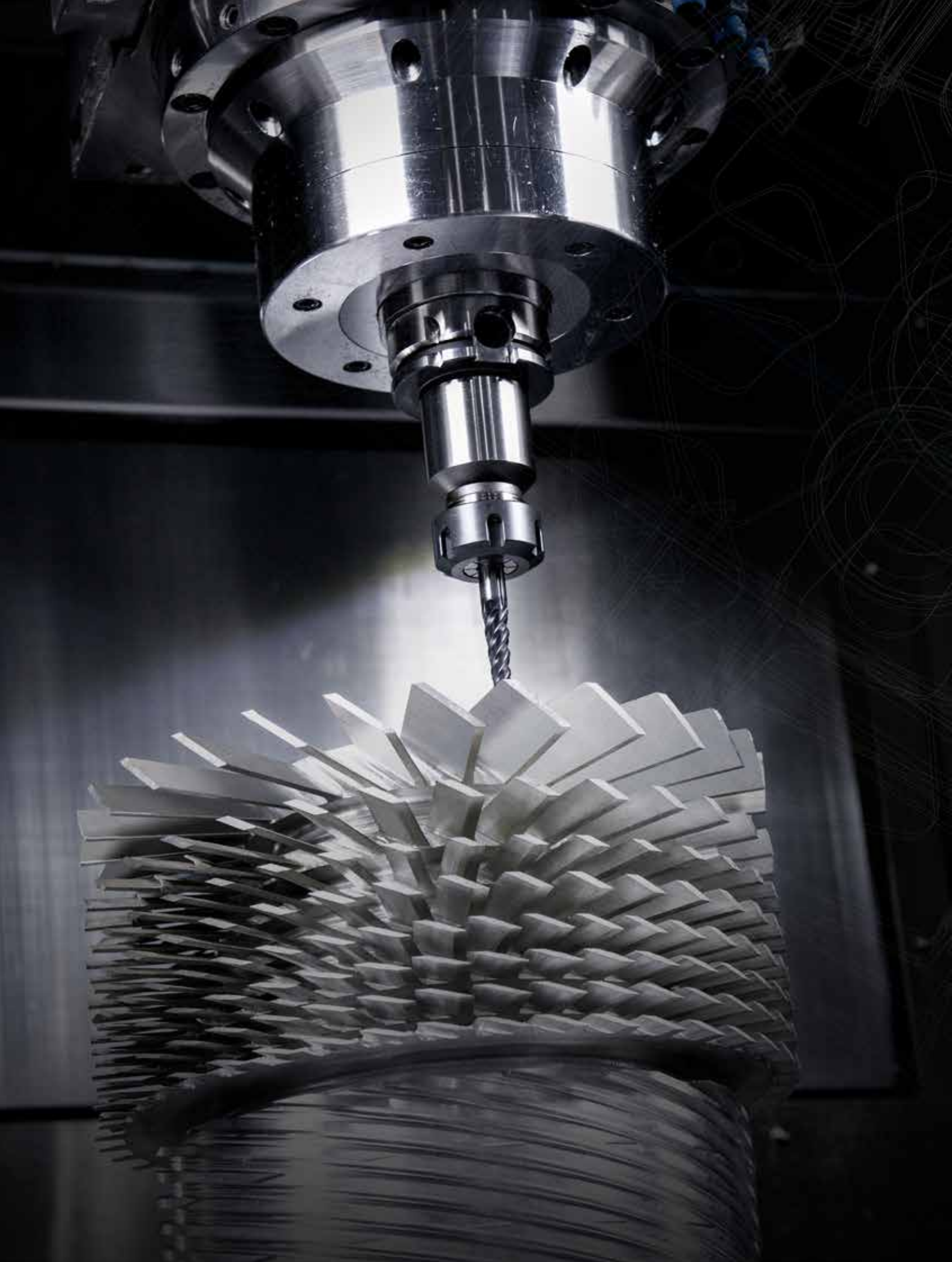

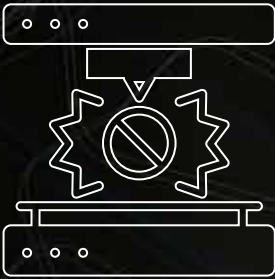

COLLISION AVOIDANCE

Machine tools cannot completely avoid the risk of collision due to programming errors, operator mistakes and other minor mishaps.

A collision can have a serious impact on the performance of a machine tool's feed axis and spindle, causing considerable losses in terms of lost production, repair costs, etc.

Obviously, the 5-axis machining center is more vulnerable to the risk of collision than the 3-axis machining center, and also tends to sustain far greater damage in the event of a collision.

That is why many buyers of 5-axis machining centers decide to pay a significant amount of money to buy a collision avoidance system generally offered by the manufacturers as an optional feature.

HYUNDAI WIA, however, is committed to ensuring that our customers can operate our machine tools in the safest environment.

As part of our efforts to fulfill such a commitment, HYUNDAI WIA's XF series is equipped with a collision avoidance system as a standard feature.

※ This function is limited to the body of the machine. Collision prevention of the workpiece and jig is not provided.

SPECIFICATIONS

Standard & Optional

● : Standard ○ : Option ☆ : Prior Consultation - : Non Applicable

Spindle		XF6300	XF8500
9,000 rpm	Built-in	-	○
15,000 rpm	Built-in	●	●
24,000 rpm	Built-in	○	○
30,000 rpm	Built-in	-	○
40,000 rpm	Built-in	○	-
Spindle cooling system		●	●
ATC			
ATC extension	34	●	●
	68	○	○
	102	○	○
Tool shank type	HSK A63	●	●
	HSK E40 (30K, 40K)	●	●
U-center	D'andrea	☆	☆
Table & Column			
Tap type table		☆	☆
T-slot table		●	●
DDM NC rotary table (simultaneous 5 axis)		●	●
Gear NC rotary table(3+2 axis machining suggest)		○	-
Turning table (800 rpm)		-	○
Coolant System			
Std. coolant (flood coolant)		●	●
Bed flushing coolant		●	●
Through spindle coolant (25 ℓ (6.6 gal))	20bar (290 psi)	○	○
	30bar (435 psi)	○	○
	70bar (1,015 psi)	○	○
Shower coolant		☆	●
Gun coolant		○	○
Air gun		○	○
Cutting air blow		●	●
Tool measuring air blow		●	●
Air blow for automation		☆	☆
Thru MQL device (without MQL)		☆	☆
Coolant chiller (Sub tank)		☆	☆
Power coolant system (for automation)		☆	☆
Chip Disposal			
Coolant tank	Cabin (470 ℓ)	○	○
	Separate Type (1,200 ℓ (317 gal))	●	●
Chip conveyor (Wedge wire type)	Left	●	●
	Right	☆	☆
	Rear	☆	☆
Special chip conveyor (Drum filter)		☆	☆
Chip wagon	Standard (180 ℓ [47.5 gal])	○	○
	Swing (200 ℓ [52.8 gal])	○	○
	Large Swing (290 ℓ [76.6 gal])	○	○
	Large Size (330 ℓ [87.2 gal])	○	○
	Customized	○	○
Electric Device			
Call light	1color : ■	○	○
Call light & buzzer	3color : ■ ■ ■ B	●	○
Work light		●	●
Electric cabinet light		○	○
Remote MPG		●	●
3 axis MPG		○	○
Electric circuit breaker		○	○
AVR (Auto voltage regulator)		☆	☆
Transformer	65kVA	○	○
Auto power off		●	●
ETC			
Tool box		●	●
Customized color	Need for Munsel No.	☆	☆
CAD & CAM software		☆	☆

Safety Device		XF6300	XF8500
Collision Avoidance		●	●
Total Splash Guard		●	●
Door Interlock		●	●
Controller			
SIEMENS 840D sl		●	○
HYUNDAI-ITROL+		○	●
HEIDENHAIN TNC640		○	○
S/W - SIEMENS, HYUNDAI-ITROL+			
Machine guidance (HW-MCG)		●	●
Tool Monitoring (HW-TM) SIEMENS/ITROL+		☆/●	☆/●
DNC Software (HW-eDNC)		○	○
Spindle Heat Distortion Compensation (HW-TDC)		●	●
Spindle Warm up Function (HW-WARMUP)		●	●
Energy Saving System (HW-ESS)		-	-
Machine Monitoring System (HW-MMS)		○	○
Tool Offset Measurement (HW-TOM)		-	-
Machining Condition Selection (HW-MCS)		○	○
Adaptive Feed Control (HW-AFC) SIEMENS/ITROL+		☆/●	☆/●
Conversational Program (HW-DPRO)		-	-
S/W - HEIDENHAIN			
Advanced function set 1		●	●
Advanced function set 2		●	●
DCM collision		●	●
KinematicOpt		●	●
Display step		○	○
DXF converter		○	○
AFC : Adaptive Feed Control		○	○
KinematicComp		○	○
CTC : Cross Talk Compensation		○	○
PAC : Position Adaptive Control		○	○
LAC : Load Adaptive Control		○	○
ACC : Active Chatter Control		○	○
AVD : Active Vibration Damping		○	○
Measuring Device			
Auto work measuring device		○	○
Tool monitoring (OMARTIVE/MARPOSS)		○	○
Auto tool measuring device (Laser)	Renishaw	●	●
	BLUM	○	○
Linear scale	X/Y/Z axis	●	●
Rotary scale	A/C axis	●	●
Coolant level sensor (only for chip conveyor)		●	●
Environment			
Control air conditioner (SAMIK/AIR MAJER)		●	●
ECO energy (hydraulic device/chip conveyor shaving mode)		●	●
Dehumidifier (SAMIK)		○	○
Oil mist collector (MORE/YHB/YOUNGPOONG)		☆	○
MQL (minimal quantity lubrication)		☆	☆
Fixture & Automation			
Auto door		○	○
Auto shutter (only for automatic system)		○	○
Sub operation pannel		☆	☆
External M code 4ea		○	○
Automation interface		☆	☆
I/O extension (In & out)	16 contact	○	○
	8 contact	○	○
Hyd. Device			
Std. hyd. unit	70bar (1,015 psi)/ 4 ℓ (1 gal)	●	●
Center type hyd. supply unit	2x2(4 port)	○	○
Hyd. unit for fixture	50bar (725 psi)	☆	☆
	Customized	☆	☆

SPECIFICATIONS

Spindle Output/Torque Diagram

XF6300 Spindle		
Std.	15,000 rpm	HSK-A63
Opt.	24,000 rpm	
	40,000 rpm	HSK-E40

XF8500 Spindle		
Std.	15,000 rpm	HSK-A63
Opt.	9,000 rpm	
	24,000 rpm	HSK-E40
	30,000 rpm	

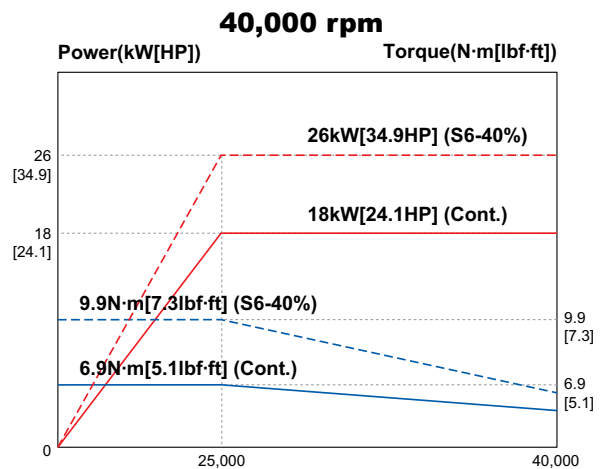
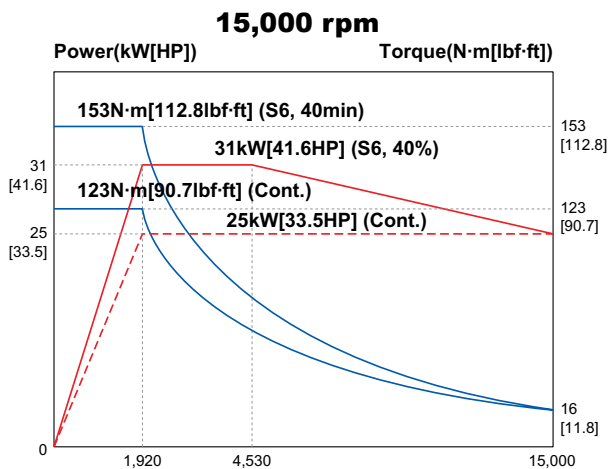
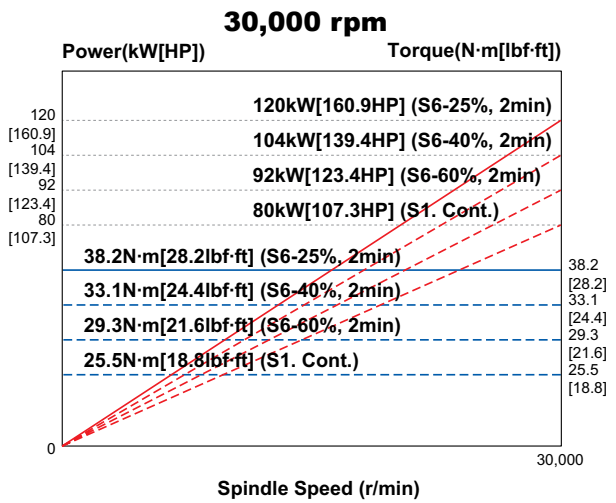
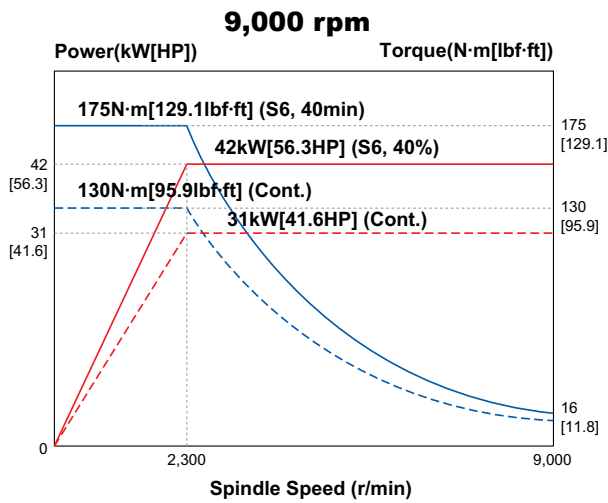
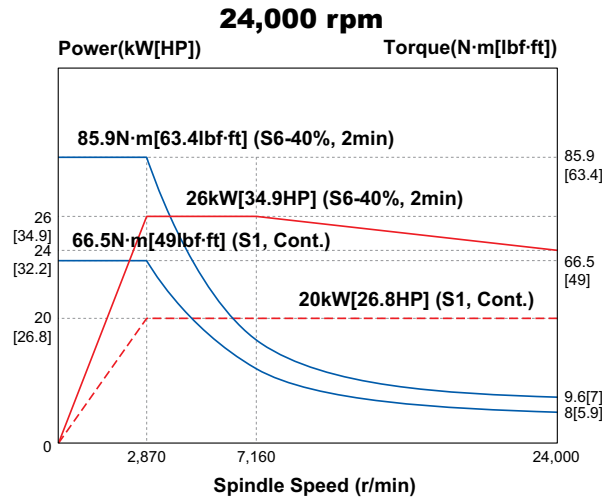

SPECIFICATIONS

Spindle & Table Travel Range

unit : mm (in)

XF6300

Tilting : A-axis 0°

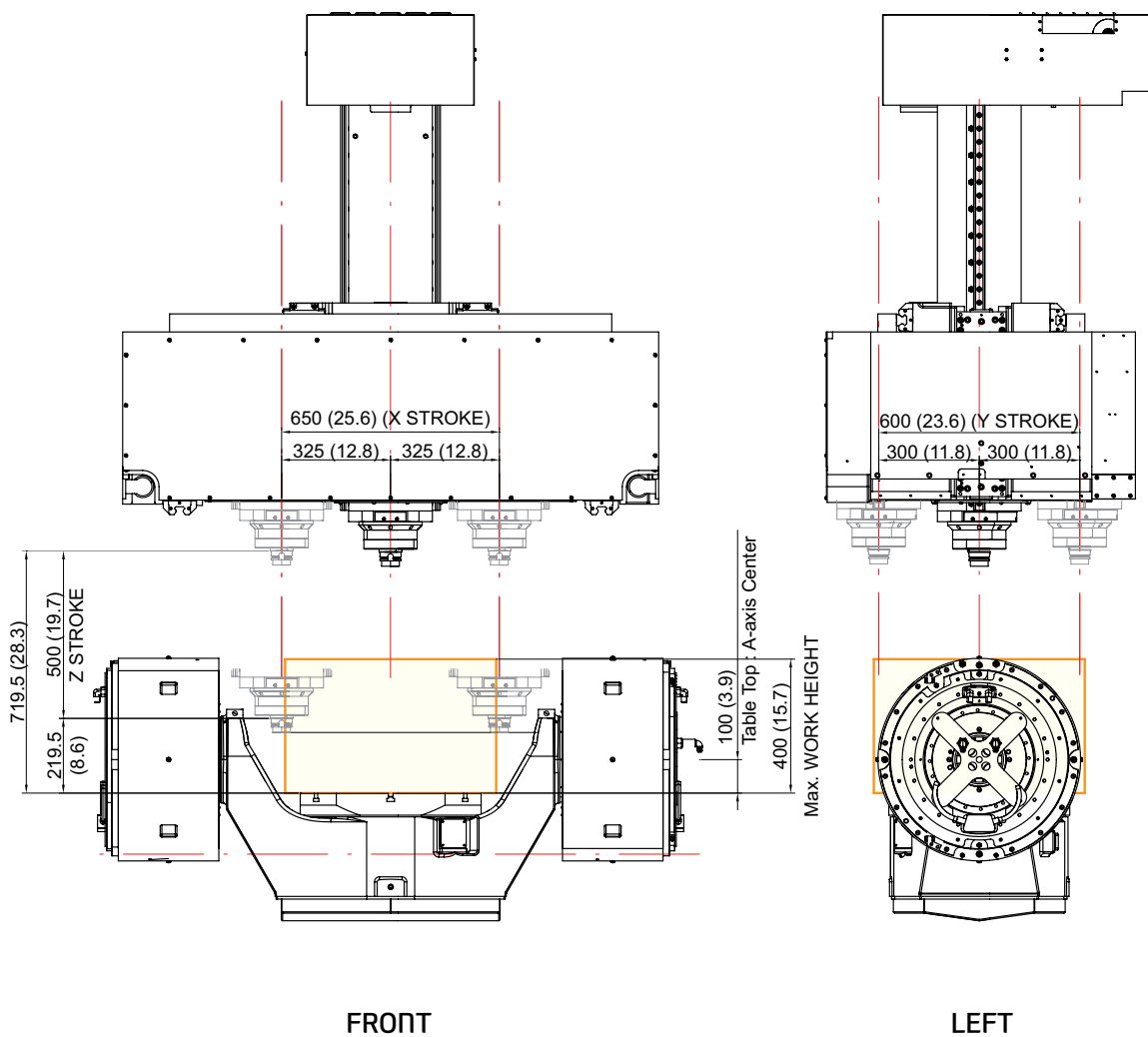

SPECIFICATIONS

Spindle & Table Travel Range

unit : mm (in)

XF6300

Tilting : A-axis -90°

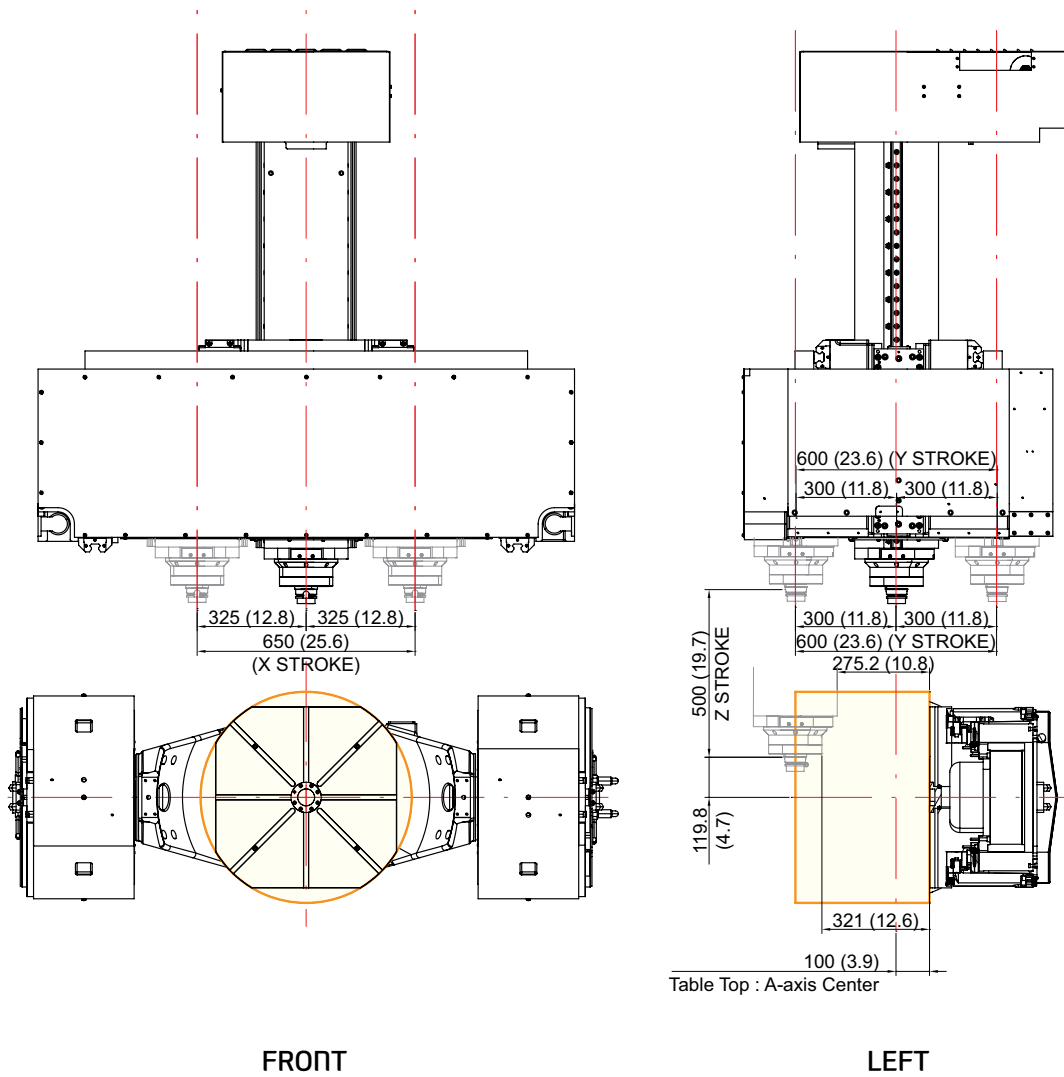

SPECIFICATIONS

Spindle & Table Travel Range

unit : mm (in)

XF8500

Tilting : A-axis 0°

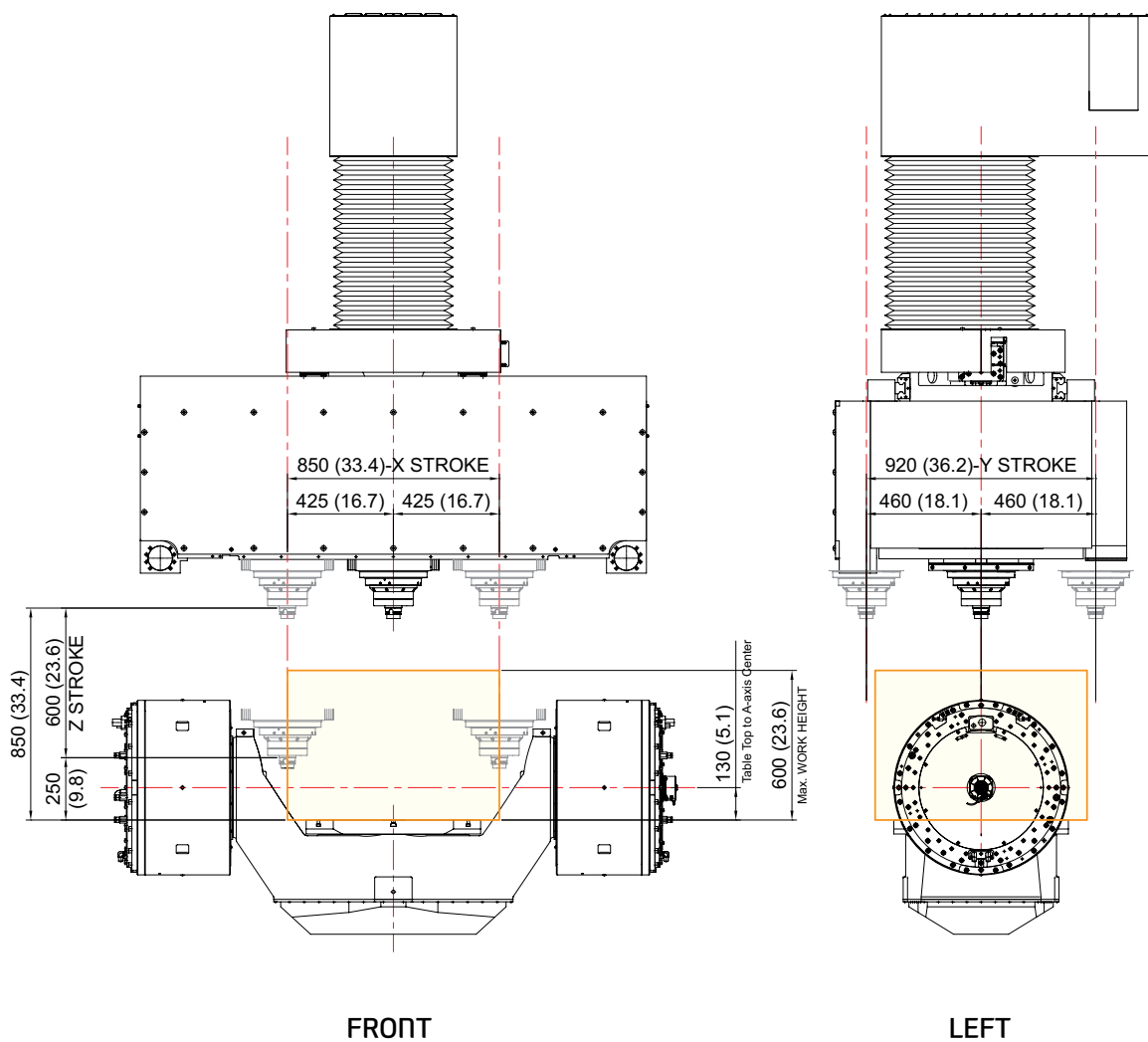

SPECIFICATIONS

Spindle & Table Travel Range

unit : mm (in)

XF8500

Tilting : A-axis -90°

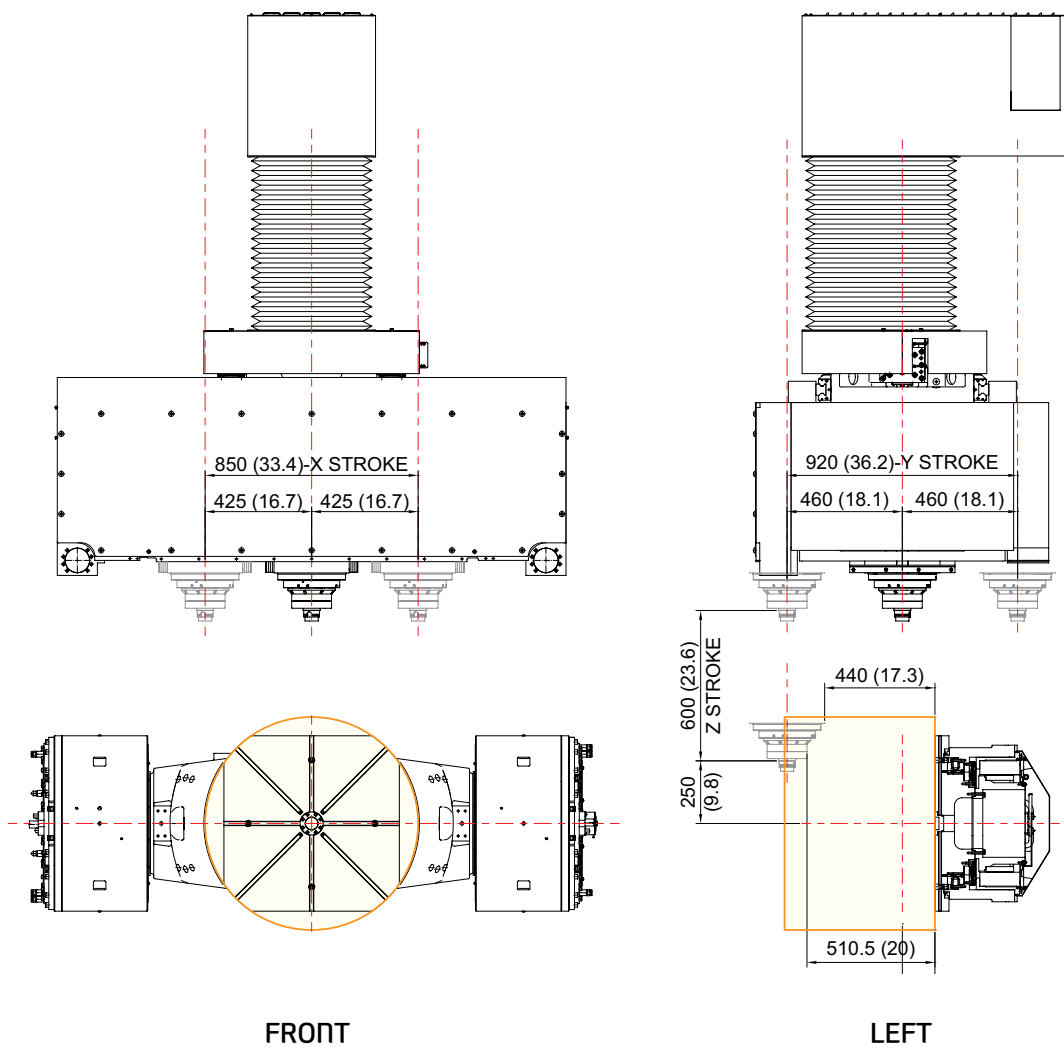

SPECIFICATIONS

Table Dimensions

unit : mm (in)

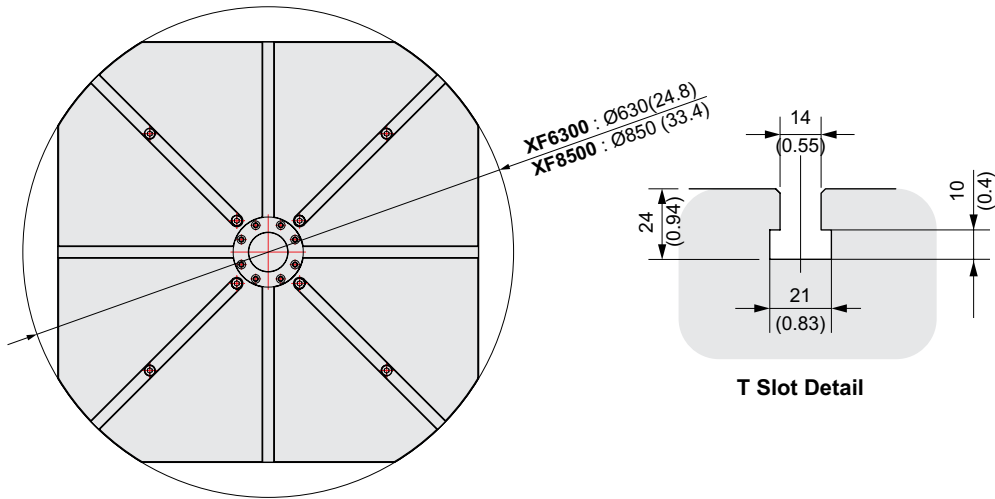

Tool Shank

unit : mm (in)

HSK-A63 (9,000rpm / 15,000rpm / 24,000rpm)

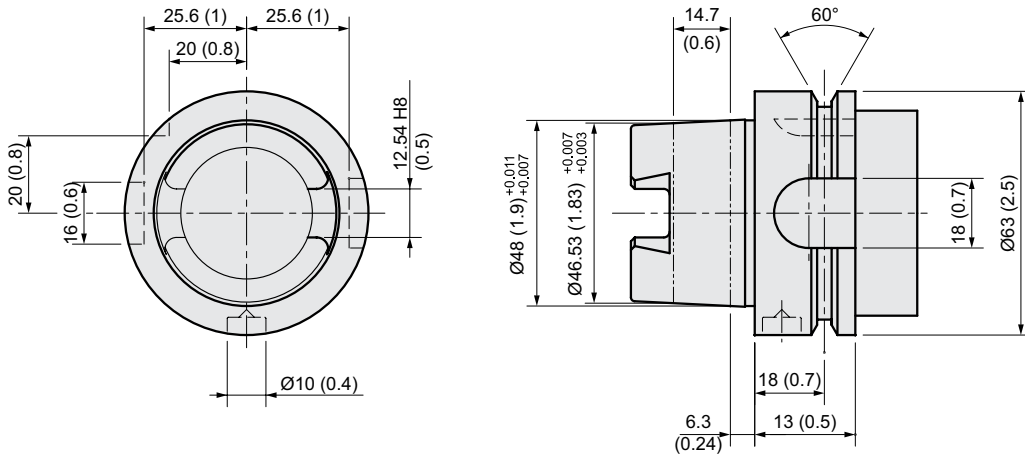

HSK-E40 (30,000rpm / 40,000rpm)

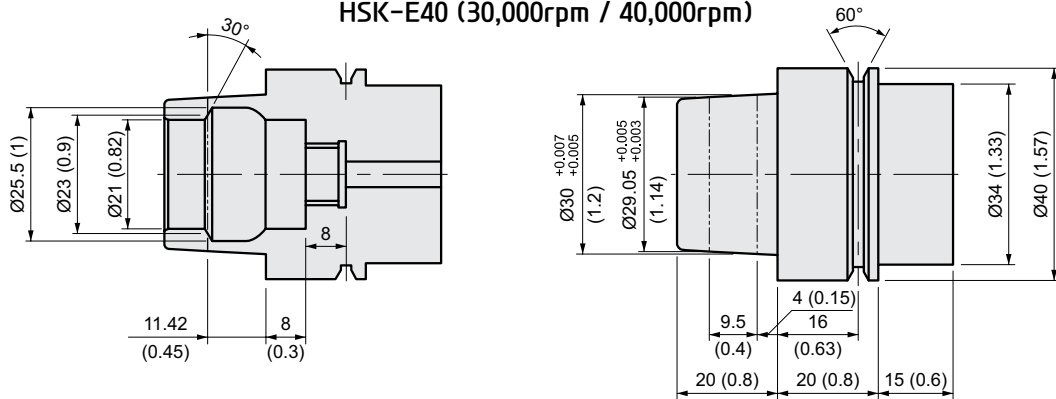

SPECIFICATIONS

External Dimensions

unit : mm (in)

XF6300

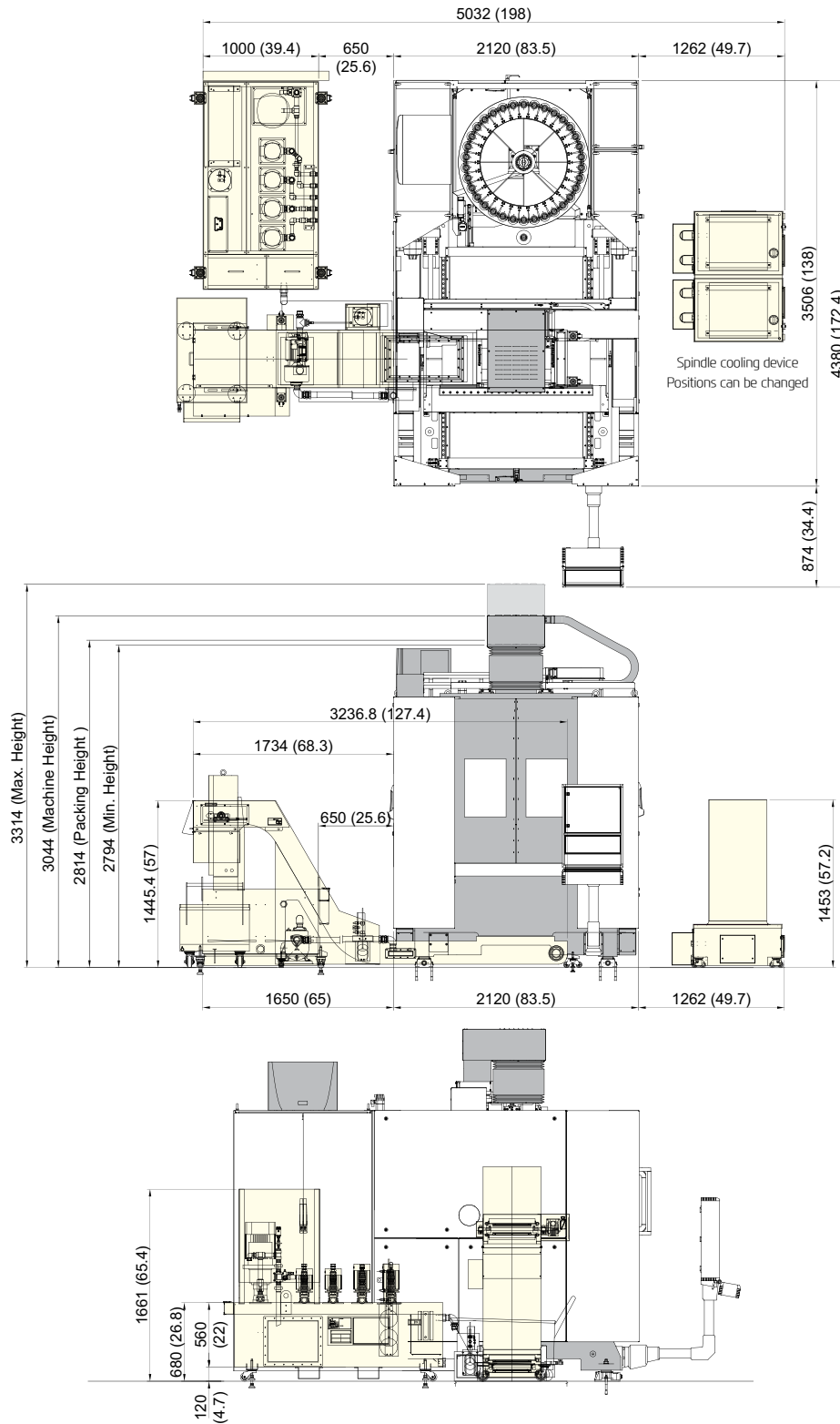

SPECIFICATIONS

External Dimensions

unit : mm (in)

XF8500

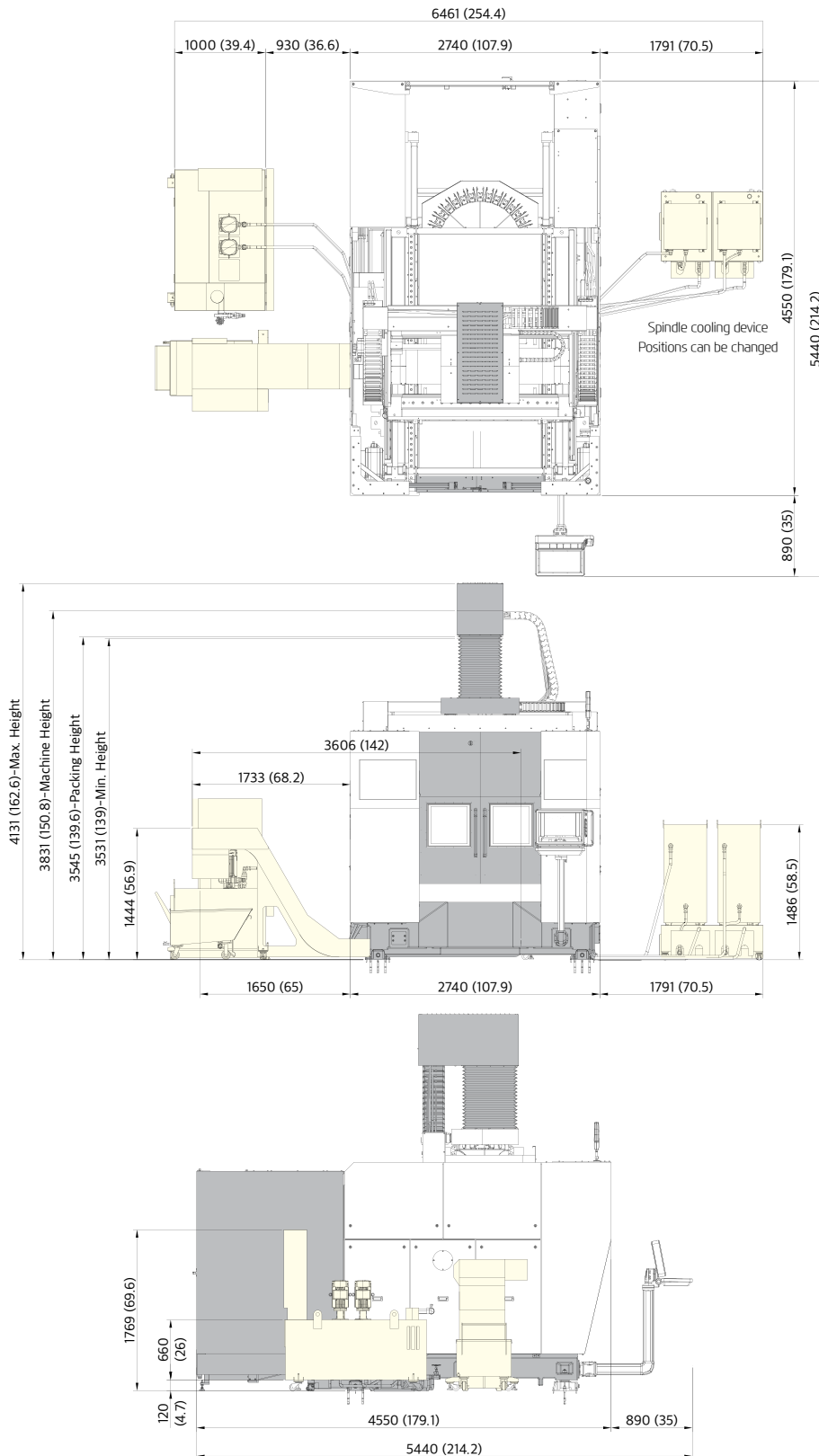

SPECIFICATIONS

Specifications

[] : Option

MODEL			XF6300	
TABLE	Table Size	mm(in)	Ø630 (Ø24.8")	
	Maximum Load Capacity	kg(lb)	Max. 600 (1,323)	
	※ Max. Machining Height(LxH)	mm(in)	Ø800×500 (Ø31.5"×19.7")	
	Table Driving Method	mm(in)	DDM [GEAR]	
SPINDLE	Spindle Taper	-	HSK-A63 [40K : HSK-E40]	
	Spindle RPM	r/min	15,000 [24,000] [40,000]	
	Spindle Power Output (Max./Cont.)	kW(HP)	31/25 (41.6/33.5) [26/20 (35/27)] [26/18 (35/24)]	
	Spindle Torque (Max./Cont.)	N·m(lbf·ft)	153/123 (112.8/91) [85.9/66.5 (63.4/49)] [9.9/6.9 (7.3/5)]	
	Spindle Driving Method	-	BUILT-IN	
FEED	Travel	X/Y/Z Axis	mm(in)	650/600/500 (25.6"/23.6"/19.7")
		A/C Axis	deg	150° (-30°~+120°)/360°
	Distance from Table Top to SP. Nose	mm(in)	220 (8.7") ~ 720 (28.3")	
	Rapid Traverse Rate	X/Y/Z Axis	m/min(ipm)	SIEMENS 840D sl : 60/60/60 (2,362/2,362/2,362) [HEIDENHAIN TNC640 : 50/50/50 (1,967/1,967/1,967)]
		A/C Axis	r/min	DDM : 70/110 [Gear : 25/50]
	Slide Type	-	ROLLER GUIDE	
ATC	Number of Tools	ea	34 [68, 102]	
	Tool Shank	-	HSK-A63 [40K : HSK-E40]	
	Max. Tool Dia. (W/T Adjacent Tool)	mm(in)	Ø90/Ø125 (Ø3.5"/Ø4.9")	
	Max. Tool Length	mm(in)	300 (11.8)	
	Max. Tool Weight	kg(lb)	8 (17.6) [40K : 1.5 (3.3)]	
	Tool Change Time	C-C	sec	4.5
	Tool Selection Method	-	FIXED / RANDOM	
TANK CAPACITY	Coolant Tank	ℓ (gal)	1,200 (317) {Propriety Capacity : 800 (211.3)}	
	Lubricating Tank	ℓ (gal)	2 (0.5)	
	Hydraulic Tank	ℓ (gal)	4 (1)	
POWER SUPPLY	Electric Power Supply	KVA	73	
	Thickness of Power Cable	Sq	OVER 50	
	Voltage	V/Hz	380/60	
MACHINE	Floor Space (L×W)	mm(in)	5,032×4,380 (198"×172.4")	
	Machine Size (L×W)	mm(in)	2,120×4,380 (83.5"×172.4")	
	Height	mm(in)	3,045 (120")	
	Weight	kg(lb)	11,000 (24,251)	
CNC	Controller	-	SIEMENS 840D sl [HEIDENHAIN TNC640] [HYUNDAI-iTROL ⁺]	

※ If the machining area exceeds Ø630 × 400(Ø248"×15.7"), some interference may occur. Please also check the interference area on page 36 of the catalog. Specifications are subject to change without notice for improvement.

SPECIFICATIONS

Specifications

[] : Option

MODEL			XF8500	
TABLE	Table Size	mm(in)	Ø850 (Ø33.4")	
	Maximum Load Capacity	kg(lb)	1,000 (2,205)	
	※ Max. Machining Height(LxH)	mm(in)	Ø1,000×600 (Ø39.4"×23.6")	
	Table Driving Method	mm(in)	DDM	
SPINDLE	Spindle Taper	-	HSK-A63 [30K : HSK-E40]	
	Spindle RPM	r/min	15,000 [9,000] [24,000] [30,000]	
	Spindle Power Output (Max./Cont.)	kW(HP)	31/25 (41.6/33.5) [42/31(56.3/41.6)] [26/20 (35/27)] [120/80 (160.9/107.3)]	
	Spindle Torque (Max./Cont.)	N·m(lbf·ft)	153/123 (112.8/91) [175/130 (129/95.9)] [85.9/66.5 (63.4/49)] [38.2/25.5 (28.2/18.8)]	
	Spindle Driving Method	-	BUILT-IN	
FEED	Travel	X/Y/Z Axis	mm(in)	850/920/600 (33.4"/36.2"/23.6")
		A/C Axis	deg	150° (+30°~-120°)/360°
	Distance from Table Top to SP. Nose	mm(in)	250~850 (9.8"~33.4")	
	Rapid Traverse Rate	X/Y/Z Axis	m/min(ipm)	45/45/45 (1,772/1,772/1,772)
		A/C Axis	r/min	50/100 (DDM)
	Slide Type	-	ROLLER GUIDE	
ATC	Number of Tools	ea	PICK UP : 34 [TWIN ARM : 68, 102]	
	Tool Shank	-	HSK-A63 [30K : HSK-E40]	
	Max. Tool Dia. (W/T Adjacent Tool)	mm(in)	Ø90/Ø125 (Ø3.5"/Ø4.9")	
	Max. Tool Length	mm(in)	300 (11.8)	
	Max. Tool Weight	kg(lb)	8 (17.6) [30K : 1.5 (3.3)]	
	Tool Change Time	C-C	sec	6.8
	Tool Selection Method	-	FIXED / RANDOM	
TANK CAPACITY	Coolant Tank	ℓ (gal)	1,200 (317) {Propriety Capacity : 800 (211.3)}	
	Lubricating Tank	ℓ (gal)	2 (0.5)	
	Hydraulic Tank	ℓ (gal)	4 (1)	
POWER SUPPLY	Electric Power Supply	kVA	73	
	Thickness of Power Cable	Sq	OVER 50	
	Voltage	V/Hz	380/60	
MACHINE	Floor Space (L×W)	mm(in)	4,907×5,440 (193.2"×214.2")	
	Machine Size (L×W)	mm(in)	2,740×5,440 (107.9"×214.2")	
	Height	mm(in)	3,831 (150.8)	
	Weight	kg(lb)	21,000 (46,297)	
CNC	Controller	-	HYUNDAI-iTROL ⁺ [HEIDENHAIN TNC640]	

※ If the machining area exceeds Ø850×600(Ø33.4"×23.6"), some interference may occur. Please also check the interference area on page 38 of the catalog.
Specifications are subject to change without notice for improvement.

CONTROLLER

HYUNDAI-iTROL+ | SIEMENS 840D sl

Control Function		Programming Input & Interpolation Function	
Controlled axis	10 axis	Scaling / Rotation	
Simultaneous controllable axis	5 axis (max 20 axis)	Inch / Metric conversion	
Least Command/input	0.0001mm / 0.0001inch	Conversational cycle program	22 ea
Feed Function		Block search	
Feedrate / Rapid traverse override	0 - 120%	Macro	
Tool Function		Read/Write system variable	
Tool radius comp.		Background editing	
Zero offset (G54, G55, G56, G57, G58, G59)	6ea (Max:100ea)	Miscellaneous functions	M - code
Programmable zero offset		Skip	
3D tool radius compensation		Program stop	M00, M01, M02, M30
Display		Lookahead, jerk limitation feed & forward control	
Language	Chinese simplified, English, French German, Italian, Spanish	Helical interpolation	
CRT/MDI	TFT 19" color	COMPACAD, COMPCURB	
Screen saver		Cylindrical interpolation	
Spindle Function		Work coordiante interpolation	
Spindle override	50% - 120%	Interactive program	
Spindle orientation		Fanuc program exe.	
Spindle speed limitation		Machining package milling	
Rigid tapping		Protection Function	
Manual Operation		Emergency stop	
Manual handle/jog feed		Soft limit	
Reposition		Contour monitoring	
Reference approach	Ref 1, 2 approach	Program protection	
Spindle control	Start, stop, rev, jog, ort.	Automation Support Function	
Auto Operation		Actual speed display	
Single block		Tool life management	Time, parts
Feed hold		Work count	Internal
Optional block skip		Language	
Machine lock		Two language switchable	Chinese traditional, Czech, Danish Dutch, Finnish, Hungarian, Japanese Korean, Polish, Russian, Swedish Portuguese, Turkish
Dry run		DATA Transfer	
Simulation		RS 232C I/F	
Diagnosis Function		Ethernet	
Alarm display / Monitor		Option	
Programming Function		Display	With harddisk
Part program storage length	10MB	Data transfer	Only PCU50
Program name	23 Digits		
Subroutine call	7 Level		
Absolute/incremental command	G90 - G91		

HYUNDAI-iTROL+ Native Smart Software

Standard Specification	
Home screen	A launcher function similar to the smart device's home screen
Remote viewer	Remote access to other devices, office PCs, etc., and management of access lists
Manual viewer	PDF manuals for machines, NC, and iTROL+
Calculator	2-points or 3-points center calculation, machining condition calculation
Machine monitoring	Visualized machining status
Job document viewer	Viewer function designed to check work documents such as work instruction and work schedule
Factory monitoring	Real-time monitoring of the machining status of other in-factory machines connected via OPC-UA
Regular check	Inspection list by period, and informs about impending inspections
Energy saving	Energy saving functions (such as Machine Ready power save and work light automatic off), and graphic expression of energy consumption
Machining history	Real-time storage of important machine information (spindle load, tool number, etc.)
Touch MCP	Physical MCP implemented in HMI to resolve the physical limitations
Side screen	All-time display of the frequently used coordinate system, frequently-used expressions, etc. on the left to improve work convenience
ATC recovery	Help screen designed to solve the tool change problems
Tool monitoring & AFC	Real-time monitoring of tool status, and control of machining speed adjustment according to load
Alarm Guidance	Provide corrective measure for the alarm with PLC I/O status and save 4-month history of the alarm
Collision avoidance for manual operation mode	Function designed to prevent machine/workpiece collision during the manual operation mode (optional)

Figures in inch are converted from metric values.

The SIEMENS controller specifications are subject to change based on the policy of company CNC supplying.

SPECIFICATIONS

HEIDENHAIN TNC640 Standard

Axes	
Controlled axes	10 Axes (Max. 18 Axes)
Simultaneously controllable axes	5 Axes.
Rotary Controlled axes	3 Axes (Max. 3 Axes)
Least command increment	0.0001 mm / 0.0001 ° (Option : 0.00001 mm / 0.00001 °)]
Display unit	19-inch color TFT (Option : 15-inch color TFT)]
Program memory	21GB (SSDR solid state disk)
Block processing time	0.5 ms
Path interpolation time	3 ms
Fine interpolation time	0.2 ms
Position controller time	0.2 ms
Speed controller time	0.2 ms
Current controller time	100 us (5000 hz)
Encoder	Absolute EnDat 2.2
Commissioning and diagnostics	
Data interface	Ethernet 2x1000 BASE-T 4xUSB 3.0 RS-232-C (max. 115200 baud)
Machine Function	
Look ahead	5,000 Block
HSC filters	
Switching the traverse ranges	
User Function	
Program input	HEIDENHAIN conversational DIN/ISO
Position entry	Nominal position for lines and arcs in Cartesian / Polar coordinates Incremental / absolute dimensions Display / entry in mm or inch
Tool compensation	Tool radius in th working plane and tool length Radius-compensated contour for up o 99 blocks (M120) 3-dimensional tool-radius compensation for changing tool data without having to recalculate an existing program
Tool tables	Multiple tool tables with any number tools
Cutting data	Automatic calculation of spindle speed, cutting speed, feed per tooth / revolution
Constant contour speed	Relative to the path of the tool center Relative to the tool's cutting edge
Parallel operation	Creating program with graphical support while another program is being run Motion control with smoothed jerk
3D machining	3D tool compensation through surface normal vectors Tool Center Point Management (TCPM) Keeping the tool normal to the contour Tool radius compensation normal to the tool direction Manual traverse in the active tool-axis
Rotary table machining	Programming of cylindrical contours as if in two axes Feed rate in distance per minute
Contour elements	Straight line Chamfer Circular path Circle center Circle radius Tangentially connecting circular arc Corner rounding
FK free contour programming	in HEIDENHAIN conversational format with graphic support for workpiece drawings not dimensioned for NC Subprograms
Program jumps	Program section repeats Calling any program as a subprogram
Coordinate transformation	Datum shift, rotation, mirror image, scaling factor (axis-specific)
Q parameters programming with variables	Mathematical functions Logical operations Calculating with parentheses
Q parameters programming with variables	Absolute value of a number, constant n, negation, truncation of digits Functions for calculation of circles Functions for text processing

Figures in inch are converted from metric values.

The SIEMENS controller specifications are subject to change based on the policy of company CNC supplying.

SPECIFICATIONS

HEIDENHAIN TNC640 Standard

User Function	
Fixed cycle	Drilling, tapping, rigid tapping
	Peak drilling, reaming, boring, centering
	Milling internal and external threads
	Clearing level and oblique surfaces
	Multioperation machining of straight and circular slots
	Multioperation machining of rectangular and circular pockets
	Cartesian and polar point patterns
	Contour train, contour pocket
	Contour slot with trochoidal milling
	Engraving cycle
Programming aids	Calculator
	Complete list of all current error messages
	Context-sensitive help function for error
	TTCguide : The integrated help system
	Graphic support for programming cycles
CAD viewer	Display of CAD data formats on th TNC
Teach-In	Actual positions can be transferred directly into the NC program
Test graphics Display modes	Graphic simulation
	Plan view /projection in 3planes /3D view
	Magnification of details
3D line graphics	For verification of programs created offline
2D pencil-trace graphics	2D pencil-trace graphics
Program-run graphics display moded	Graphic simulation during real-time maching
	Plan view /projection in 3planes /3D view
Machining time	Calculation of machining time in the Test Run operating mode
Machining time	Display of the current machining time in the Program Run operating modes
Returning to the contour	
Datum management	One table for storing reference point
Datum tables	Multiple datum tables for storing workpiece-specific datums
Language	English / German / Korean / French / Italian / Spanish / Portuguese / Swedish / Danish / Finnish / Dutch /
	Polish / Hungarian / Russian / Chinese / Chinese_Trad /Slovenian / Norwegian / Czech / Romanian / Slovak / Turkish
Interpolation	
Linear	5 Axes
Circular	3 Axes
Spline	(Max. 5 Axes)
Helical	
Cylinder surface	
Rigid tapping	

HEIDENHAIN S/W OPTION (As a standard)

Advanced function set 1	1. Rotary table machining / 2. Coordinate transformations / 3. Interpolation
Advanced function set 2	1. 3-D machining / 2. Interpolation
DCM : Dynamic Collision Monitoring	Collision monitoring for safety machining operation
Kinematic Opt	Easy calibration of rotary axes

HEIDENHAIN S/W OPTION (Customer Option)

Display step (micron control)	Linear axis : 0.1 μm (std) \rightarrow 0.01 μm (with option #23) / Angular axis : 0.0001° (std) \rightarrow 0.00001° (with option #23)
DXF converter	Importing contours and machining options from DXF files
AFC : Adaptive Feed Control	Controls the feed rate depending on the machine situations
Kinematic comp (3-D spatial compensation)	Improves machine accuracy by compensation of geometry errors
CTC : Cross Talk Compensation	Compensation of position errors through axis coupling to improve quality and accuracy
PAC: Position Adaptive Control	Position-dependent adaptation of control parameters
LAC : Load Adaptive Control	Adjust the parameters of the feedforward control to the current mass of the workpiece
ACC : Active Chatter Control	Reduces chattering during heavy cutting to decrease tool mark and machine load
AVD : Active Vibration Damping	Vibration damping by adjusting of the jerk for better surfaces

Figures in inch are converted from metric values.

The SIEMENS controller specifications are subject to change based on the policy of company CNC supplying.

HYUNDAI WIA

XF-6300

EN-GJL 300

12615

E6

CORPORATION

ALWAYS BY YOUR SIDE

The technology of HYUNDAI WIA in everyday live.

HYUNDAI WIA exists, not in a special moment of your life, but in your normal everyday life in places that can't be seen. Like water and air which exists everywhere, but is essential to life, the core technology of HYUNDAI WIA lies inside the products you use in your everyday life.

HYUNDAI WIA, the Machine Tool Industry Leader playing a key role in supporting all industries!



You Tube HYUNDAI WIA MT

www.youtube.com/HYUNDAIWIAMT

EXPERIENCE THE NEW TECHNOLOGY

With its top-quality HYUNDAI WIA machine tool creates a new and better world.



<http://machine.hyundai-wia.com>

HYUNDAI WIA Machine Tools
Global Links

HEADQUARTER

Changwon Technical Center/R&D Center/Factory 153, Jeongdong-ro, Seongsan-gu, Changwon-si, Gyeongsangnam-do, Korea TEL : +82 55 280 9114 FAX : +82 55 282 9114

Oversea Sales Team /R&D Center 37, Cheoldobangmulgwan-ro, Uiwang-si, Gyeonggi-do, Korea TEL : +82 31 8090 2539

OVERSEAS OFFICES

HYUNDAI WIA Machine America corp. 450 Commerce Blvd, Carlstadt, NJ 07072, USA TEL : +1-201-987-7298

HYUNDAI WIA Europe GmbH Alexander-Fleming-Ring 57, 65428 Rüsselsheim Germany TEL : +49-0-6142-9256-0

HYUNDAI WIA Machine Tools China 2-3F, Bldg6, No.1535 Hongmei Road, Xuhui District, Shanghai, China TEL : +86-21-6427-9885

India Branch Office #4/169, 1st Floor, LOTTE BLDG, Rajiv Gandhi Salai, (OMR), Kandanchavadi, Chennai - 600096, Tamilnadu, India TEL : +91-76-0490-3348

Vietnam Branch Office Flat number 05, Service and Trade Center of Viet Huong Industrial Zone, Highway 13, Thuan Giao, Thuan An, Binh Duong, Vietnam TEL : +84-3-5399-5099

2021-01 003.018 ENG