

HD

SY Series

HD2200Y/2200SY | HD2600Y/2600SY | HD3100YA/SYA | HD3100Y/SY

HYUNDAI WIA Y-Axis Turning Center



Technical Leader

The CNC Turning Center HD-SY Series, designed with HYUNDAI WIA's engineering expertise to maximize productivity by enhancing rigidity and accuracy of machining.

ITEM	Main Chuck			Sub Chuck		Bed (Z-Axis)		Mill Turret	
	8"	10"	12"	5"	6"	680mm (26.8")	830mm (32.7")	BMT55P	BMT65P
HD2200Y	●					●		●	
HD2200SY	●			●		●		●	
HD2600Y		●				●		●	
HD2600SY		●		●		●		●	
HD3100YA		●					●		●
HD3100SYA		●			●		●		●
HD3100Y			●				●		●
HD3100SY			●		●		●		●

●: Standard ○: Option

HD

SY Series

Lathe with Y-axis & Box Guideways for Heavy Cutting

- Box guideways for heavy duty cutting
- 30° slanted one-piece bed structure for high rigidity
- Stabilized Unit Structure to minimize thermal displacement
- Integrated processing through synchronized control of Main/Sub spindle ('SY' Type)
- Multi-tasking operation with wedge type Y-axis BMT55P turret
- Excellent rapid traverse rate: 30m/min [1,181ipm] (Z-axis)
- Ergonomic design for convenient access to chuck and tool



Y-AXIS TURNING CENTER



APPLICATIONS & PARTS

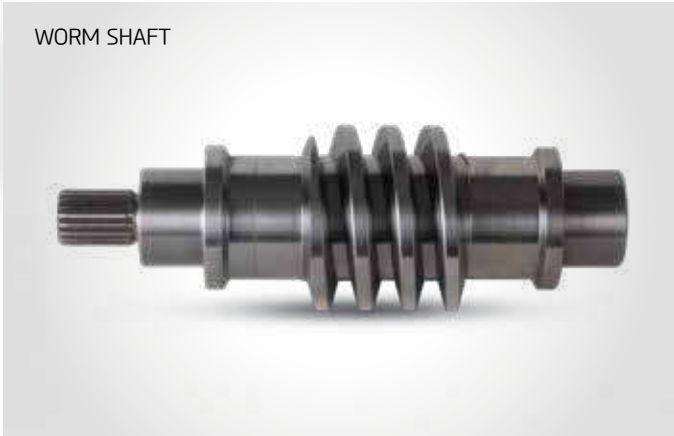

Reduced machining time by multi-tasking operation
 HD-SY Series with Y-axis makes it possible to work high-valued product with integrated processing using sub spindle and various rotary tools in short time.

WHEEL HUB



COOLING ADAPTER



HUB SHAFT



DRIVE GEAR



01 BASIC STRUCTURE

Which Can Cover All Machining Process with Only One Initial Setting

Mill Turret

- BMT55P
6,000 r/min, Ø16 (Ø5/8") {ER25}
- BMT65P
5,000 r/min, Ø25 (Ø1") {ER32}

Sub Spindle

- 5" / 6,000 r/min
- 6" / 4,500 r/min
- C-Axis Control : 0.001°

High Precision Spindle

- Integral body & heat dissipating RIB structure.
- HD2200Y/SY : 8" / 4,000 r/min
- HD2600Y/SY : 10" / 3,500 r/min
- HD3100YA/SYA : 10" / 3,500 r/min
- HD3100Y/SY : 12" / 2,800 r/min
- C-Axis Control : 0.001°

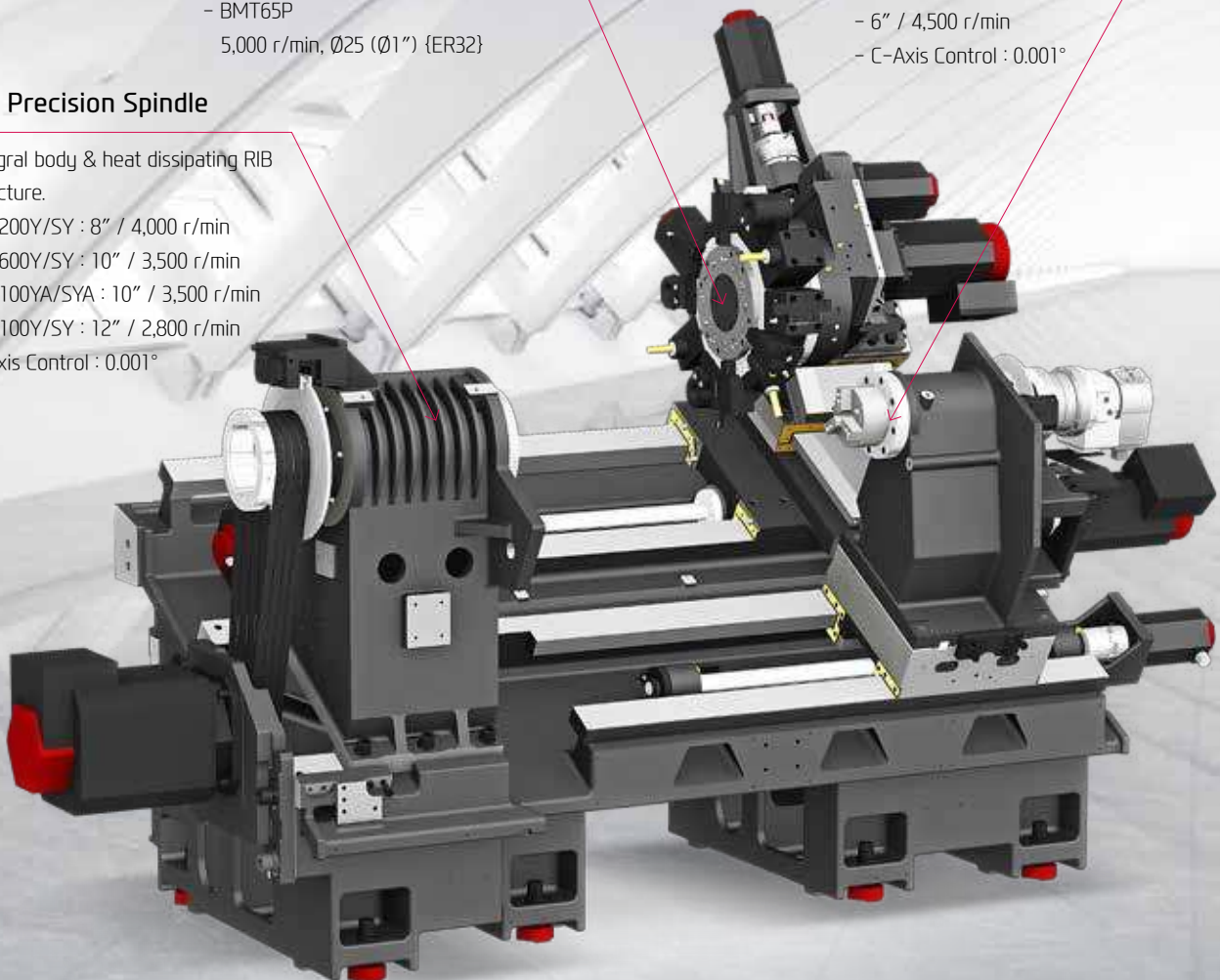

REDUCTION OF NON-CUTTING TIME BY FAST RAPID SPEED

ALL-IN-ONE TYPE OF BED

Optimal Structural Analysis

Structural analysis was applied to the design of the machine to increase the tool post body and reduce the machine's height so as to maintain the bed's dynamic rigidity even during heavy-duty cutting.

In addition, the HD-SY Series bed slope is pitched at 30 degrees to ensure more stable machining.



Integrated Coolant Tank

The structure is designed with the coolant tank installed at the bed front for improved convenience. Chips can be removed from the right side of the machine.

GUIDEWAY

Box Guideway

All axes of HD-SY Series are designed with Box Guideways for better travel ability. Box Guideways show great performance in offsetting vibrations caused by heavy duty cutting.

Sealed GIB Structure

X-axis of HD2200 is designed to minimize the damage of turcite from chips by applying the sealed GIB structure.

Rapid Traverse Rate (X/Y/Z/ZB)

24/10/30/24 m/min (945/394/1,181/945 ipm)

Travel (X/Y/Z/ZB)

HD2200Y/SY, HD2600Y/SY

215/110/680/680 mm

(8.5"/4.3"/26.8"/26.8")

HD3100YA/SYA, HD3100Y/SY

265/120/830/830 mm

(10.4"/4.7"/32.7"/32.7")



6-Face constraint design for improved travel capacity

02 Y-AXIS FUNCTION

The Y-Axis Function, Cutting for Complex Shaped Work-piece

HIGH PERFORMANCE Y-AXIS

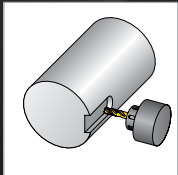

Keyway Milling

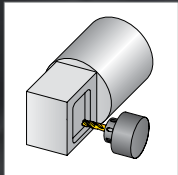

Multi-sided machining

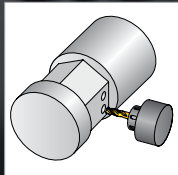

Eccentric hole machining

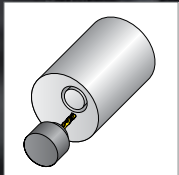

X+Y axis circular interpolation

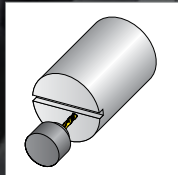

Fine Grooving

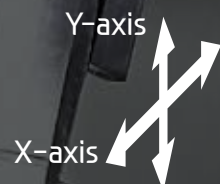

MACHINING PROCESS WITH ONLY ONE INITIAL SETTING

Y-AXIS

Wedge Type Y-Axis Structure

The HD-SY Series is designed with a wedge type Y-axis that is transferred by the simultaneous operation of the Ys-axis and the X-axis. In addition, excellent rigidity makes it possible to perform superb quality when machining a heavy-duty cutting.

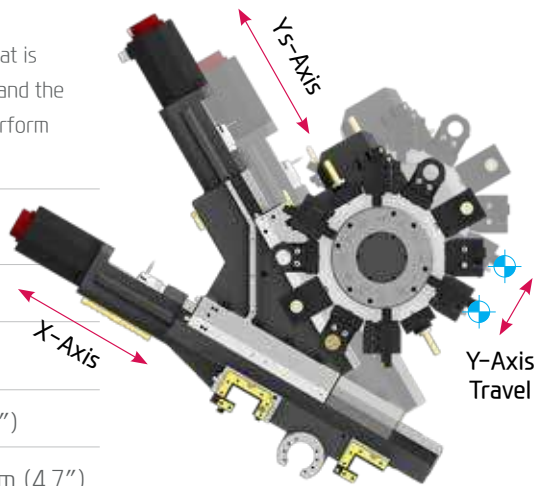

Y-axis Rapid Traverse Rate

10 m/min (394 ipm)

Y-axis Travel

HD2200Y/SY, HD2600Y/SY : 110 {±55} mm (4.3")

HD3100YA/SYA, HD3100Y/SY : 120 {±60} mm (4.7")

HD3100Y (12") Machining Capability

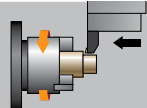
 O.D Turning (Material : S45C)	
Machining Dia.	Ø172
Machining depth	7.5 mm
Spindle rpm	389 r/mim
Cutting speed	210 m/mim
Forwarding speed	0.55 mm/rev
Chip discharging amount	866 cc/min

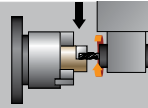
 End Mill (Material : S45C)	
Tool Dia.	Ø20 mm
Spindle rpm	675 r/mim
Forwarding speed	0.15 mm/rev
Cutting speed	86 m/mim
Machining depth	10 mm
Machining thickness	20 mm

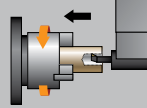
 I.D Turning (Material : S45C)	
Tool Dia.	Ø76.4
Machining depth	10 mm
Spindle rpm	750 r/mim
Cutting speed	180 m/mim
Forwarding speed	0.12 mm/rev

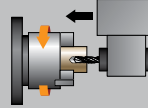
 U-Drill (Material : S45C)	
Tool Dia.	Ø63
Machining depth	15 mm
Spindle rpm	1,011 r/mim
Cutting speed	200 m/mim
Forwarding speed	0.29 mm/rev

❖ The above result might be different by types of processing circumstances.

03 HIGH PRECISION SPINDLE

Long Lasting, High Accuracy & Excellent Performance CNC Turning Center



Spindle Specifications

[] : Option

ITEM	Spindle Speed	Motor (Max./Cont.)	Torque (Max./Cont.)	Type
HD2200Y/SY	4,000 (FANUC)	18.5/15 kW (25/20 HP)	206.2/125.4 N·m (152.1/92.5 lbf·ft)	BELT
	[4,000 (ITROL)]	[22.5/15 kW (30/20 HP)]	[215/143.3 N·m (158.6/105.7 lbf·ft)]	
HD2600Y/SY	3,500 (FANUC)	18.5/15 kW (25/20 HP)	400.7/243.7 N·m (295.5/179 lbf·ft)	
	[3,500 (ITROL)]	[41.8/22 kW (56/29.5 HP)]	[679/357.4 N·m (500.8/263.6 lbf·ft)]	
HD3100YA/SYA	3,500 (FANUC)	26/18.5 kW (35/25 HP)	734/522 N·m (541.4/385 lbf·ft)	
HD3100Y/SY	2,800 (FANUC)	26/18.5 kW (35/25 HP)	1,051/672 N·m (775.2/495.6 lbf·ft)	

HEAVY DUTY CUTTING & HIGH ACCURACY

SPINDLE

Spindle for Heavy Cutting

The main spindle is designed with the same structure as that often found in larger sized machines. The combination of double cylindrical roller bearings and angular contact ball bearings leads to excellent heavy duty cutting performance. Also, machining performance is enhanced by applying ribstar belt to minimize noise and belt slipping problems.

The spindle is designed with a labyrinth structure to minimize possible bearing damage from coolant and to improve machining stability.

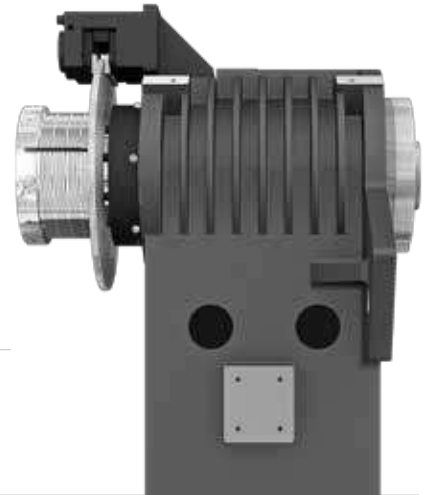

C-Axis Control

C-axis of HD-SY Series can be controlled to 0.001° which makes it possible to process various shapes.

Sub Spindle ('SY' Type)

The Belt-type sub spindle is designed to minimize thermal displacement during the continuous machining, offering from the heavy-duty cutting to the high-speed machining.

HD2200SY/2600SY 5" (6,000 r/min)

HD3100SYA/3100SY 6" (4,500 r/min)



TAIL STOCK

The HD-Y series is fitted with tailstocks as a standard for excellent machining quality.

In addition, the travel distance of quill can be as long as 120mm(4.7"), thus expanding the support area.

HD2200Y/2600Y MT#4 {Travel : 680 mm} (26.8")

HD3100YA/3100Y MT#5 {Travel : 830 mm} (32.7")



HD-SY SERIES

04 BMT TURRET

High speed, High Accuracy, Highly Reliable Servo Turret



VARIOUS DRIVEN PRECISION BMT TOOL HOLDERS

TURRET

Mill Turret

The BMT turret secures the tool with four bolts and key on the tool mounting surface of the turret, making it possible to powerfully fix the tool, ensuring high reliability in rigidity and precision.

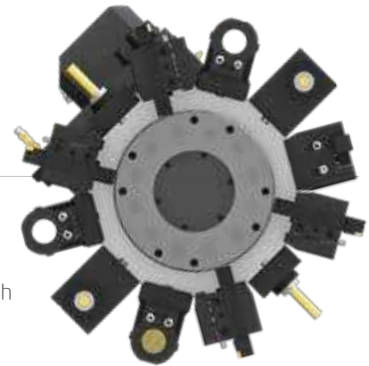

STRAIGHT MILLING HEAD



ANGULAR MILLING HEAD



Mill Tool Holder

Machining capability has increased with the addition of straight milling head tool holder, which can machine workpieces from the side, and angular milling head tool holder, which can perform I.D. operations.

BMT 55P (HD2200Y/SY | HD2600Y/SY)

- ⊙ Speed (rpm) : 6,000 r/min
- ⊙ Collet size : $\varnothing 16$ ($\varnothing 5/8''$) {ER25}
- ⊙ Indexing Time : 0.2 sec/step

BMT 65P (HD3100YA/SYA | HD3100Y/SY)

- ⊙ Speed (rpm) : 5,000 r/min
- ⊙ Collet size : $\varnothing 25$ ($\varnothing 1''$) {ER32}
- ⊙ Indexing Time : 0.2 sec/step

SPECIAL TOOL

OPTION

With the Y-axis, the HD-SY series can process high value-added products using a variety of rotating tools. In particular, there is a multi-holder for attaching a variety of tools to one holder, and an eccentric rotary tool for handling eccentric parts without additional axis travel, which can realize integration of process with one machine.

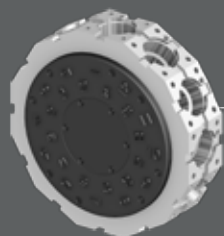

ANGLE HEAD

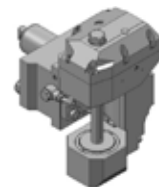

GEAR HOBBING HEAD



DOUBLE TYPE HEAD

❖ Consultation needed when ordering these options.

05 USER CONVENIENCE

Various Devices for User Friendly

BAR FEEDER SYSTEM

Bar Feeder

Bar feeder system enables automation which leads to efficiency improvement.

Long Type	: 3 m (118.1")	Short Type	: 1.5 m (59.1")
Bar Capacity	: Ø42 (1.7")	Bar Capacity	: Ø65 (2.6")



Parts Catcher

An optional parts catcher collects finished parts without the need to open the door, adding productivity, especially when a bar feeder is attached.



Auto Door

Using M-code, the doors can be automatically opened and closed which brings productivity and convenience for automation.



Parts Conveyor

The parts conveyor transfers the finished workpiece unloaded by the parts catcher for user convenience.



Auto Shutter

Using auto shutter, automation system with gantry loader is possible without opening the machine's door.

HIGH PRECISION SYSTEM



Automatic Q-Setter

Cutting tools are calibrated quickly and accurately with the addition of a q-setter. Each tool tip is touched off manually using a sensor that inputs the position automatically.



Linear Scale

Linear scales increase positioning accuracy and reduce distortion caused by thermal growth, thus ensuring a more accurate finished part



Work Probe

Workpiece coordinate values can be set automatically using the optional spindle probe.

Optional

CHIP DISPOSAL SOLUTION

Chip Conveyor

Timely and effective disposal of chips will enhance productivity as well as the working environment.



Hinge	Chip Type : Roughing Chip, Long Chip, Chip complex	Material : SS41, 45C, Cast Steel	Front-Right Direction
	Highly efficient when disposing a lot of chips. Capable of handling stringy chips..		
Scraper	Chip Type : Finely broken chip blown out	Material : cast Iron, Nonferrous	
	Convenient for shortly cut chips.		
❖ Screw	Chip Type : The lower portion of micro-chips	Material : Steel, Casting	
	Compresses and ejects chips to reduce chip Trouble.		
❖ Drum Filter	Chip Type : Powder, Micro Chip	Material : AL	
	Advantageous in precision, as the chips do not flow in to the coolant nozzle.		

❖ When ordering a screw or drum filter chip conveyor, prior consult with hyudai wia's sales person.

COOLANT UNIT & ECO SYSTEM



Standard Coolant (Nozzle)



Chuck Coolant (Upper Chuck)



Chuck Air Blow (Upper Chuck)



Air Gun

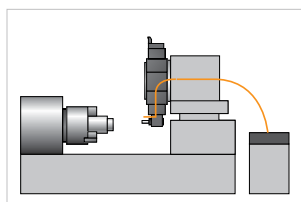

MQL : Minimal Quantity Lubrication



Oil Skimmer



Mist Collector



Grease Lubrication Device

06 HYUNDAI WIA FANUC – SMART PLUS

The Compatible All-round Control

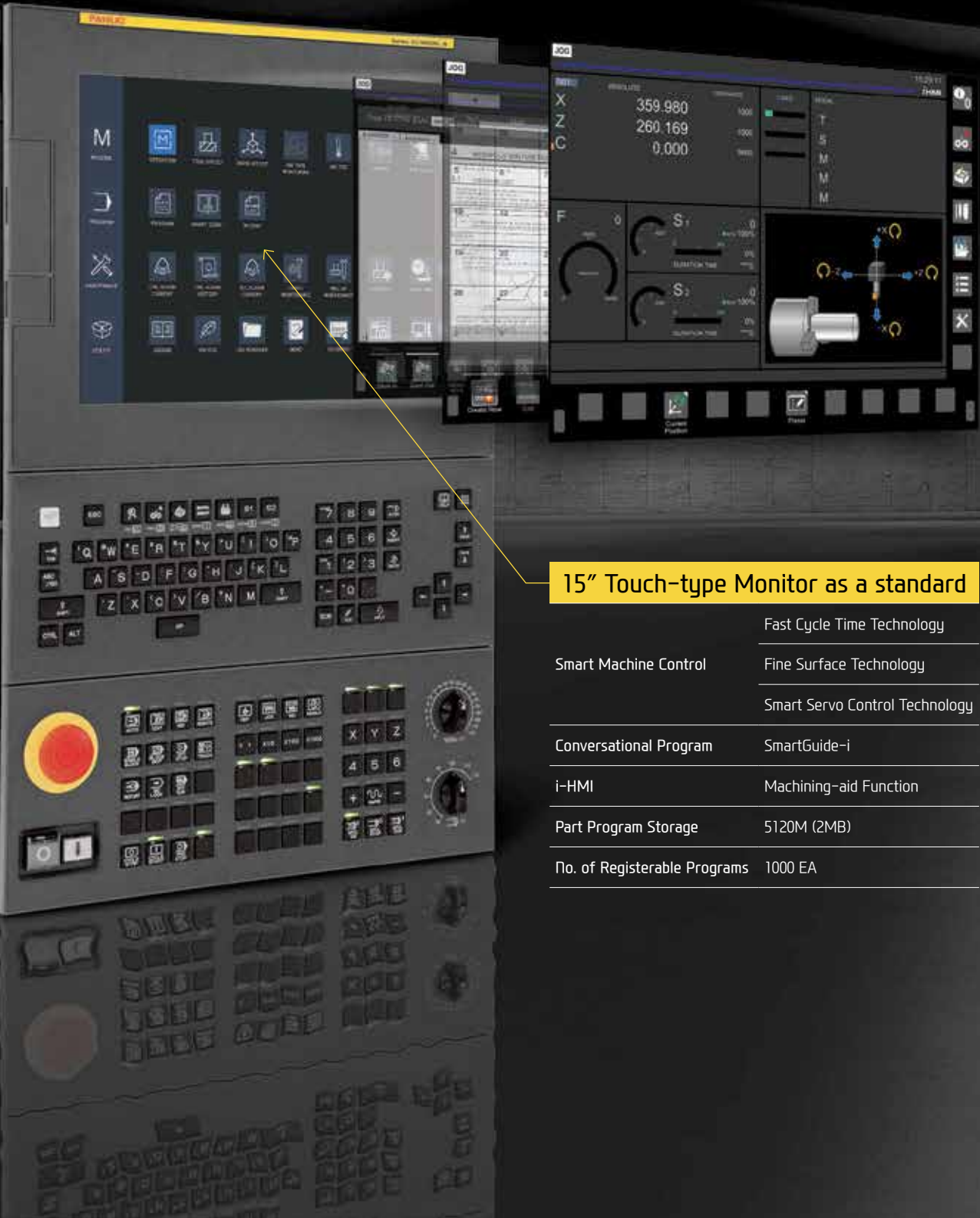

15" Touch-type Monitor as a standard

	Fast Cycle Time Technology
Smart Machine Control	Fine Surface Technology
	Smart Servo Control Technology
Conversational Program	SmartGuide-i
i-HMI	Machining-aid Function
Part Program Storage	5120M (2MB)
No. of Registerable Programs	1000 EA



SMART SOFTWARE



Dialogue Program (Smart Guide-i)

This software offers the maximum user convenience through dialogue manipulation from setup to processing. This includes writing processing programs and simulation checks.

Convenience Function S/W



1. Thermal Displacement Compensation (HW-TDC) OPTION
 This software improves processing precision by minimizing thermal deformation from changes in external environments and machining.

2. Machine Guidance (HW-MCG)
 This software offers various user convenience functions such as tool manipulation, maintenance, tool monitoring, and a pop-up/status

3. LAUNCHER
 This software offers shortcuts for quick access to specialized features and frequently used features.

4. Tool Monitoring (HW-TM) OPTION
 This tool status monitoring software monitors and protects workpiece, tools, and equipment through real-time monitoring of the motor load from machining.

Machining Support S/W



1. Premium Tool Operation
 This software offers premium graphic functions for more intuitive tool operation.

2. Manual Viewer
 This software enables users to view electronic manuals right from the tool.

3. Scheduling
 This software enables viewing/setting up directly from the tool. This allows such actions as managing customer's tool schedules and schedule notification.

4. Operation Memo
 This software is capable of managing customer notes such as tool information and issues.

SPECIFICATIONS

Standard & Optional

Spindle		HD2200Y/SY	HD2600Y/SY
Main Spindle	8"	●	-
Hollow Chuck 3 Jaw	10"	-	●
Main Spindle	8"	-	-
Solid Chuck 3 Jaw	10"	-	-
Sub SP. Hollow Chuck 3 Jaw	5"	-/●	-/●
Sub SP. Solid Chuck 3 Jaw	5"	-	-
Standard Soft Jaw (1set)		●	●
Chuck Clamp Foot Switch		●	●
2 Steps Hyd. Pressure Device		○	○
Spindle Inside Stopper		☆	☆
Cs-Axis (0.001")		●	●
Chuck Open/Close Confirmation Device		●	●
2 Steps Chuck Foot Switch		○	○
Sub Spindle Foot Switch		-/●	-/●
Turret			
Tool Holder		●	●
Mill Turret	BMT	●	●
	12 Tool	●	●
	24 Tool	○	○
Straight Milling Head (Axial)	Collet Type, 2ea	●	●
Angular Milling Head (Radial)	Collet Type, 2ea	●	●
Straight Milling Head (Axial)	Adapter Type	○	○
Angular Milling Head (Radial)	Adapter Type	○	○
Boring Sleeve		●	●
Drill Socket		○	○
U-Drill Holder		●	●
U-Drill Holder Sleeve		●	●
Angle Head		☆	☆
Tail Stock & Steady Rest			
Quill Tail Stock	MT#4	●/-	●/-
	MT#5	-	-
Built-in Tail Stock		○/-	○/-
Programmable Tail Stock		○/-	○/-
Manual Hyd. Steady Rest		-	-
Standard Live Center		●/-	●/-
High Precision Live Center		☆/-	☆/-
2 Steps Tail Stock Pressure System		☆/-	☆/-
Quill Forward/Reverse Confirmation Device		○/-	○/-
Tail Stock Foot Switch		○/-	○/-
Coolant & Air Blow			
Standard Coolant (Nozzle)		●	●
Chuck Coolant (Upper Chuck)		○	○
Gun Coolant		○	○
Through Spindle Coolant (Only for Special Chuck)		☆	☆
Turnmill Through Coolant		-	-
Chuck Air Blow	Main SP.	○	○
	Sub SP.	-/○	-/○
Tail Stock Air Blow (Upper Tail Stock)		○/-	○/-
Turret Air Blow		☆	☆
Air Gun		○	○
Through Spindle Air Blow (Only for Special Chuck)		-	-
High Pressure Coolant	0.5Bar	●	●
	6Bar	○	○
	20Bar	○	○
	70Bar	○	○
Power Coolant System (For Automation)		☆	☆
Coolant Chiller (When selecting Sub Tank Type, Chip Conveyor)		-	-
Chip Disposal			
Coolant Tank	Right	●	●
	Rear	☆	☆
Chip Conveyor (Hinge/Scraper)	Front (Right)	○	○
	Rear (Rear)	☆	☆
Special Chip Conveyor (Drum Filter)		-	-
Chip Wagon	Standard (180 ℓ [47.5 gal])	○	○
	Swing (200 ℓ [52.8 gal])	○	○
	Large Size (330 ℓ [87.2 gal])	○	○
	Customized	☆	☆
Safety Device			
Front Door Interlock		●	●
Total Splash Guard		●	●
Chuck Hydraulic Pressure Maintenance Interlock		☆	☆

● : Standard ○ : Option ☆ : Prior Consultation - : Non Applicable

Electric Device		HD2200Y/SY	HD2600Y/SY
Call Light	1Color : ●	●	●
Call Light & Buzzer	3Color : ● ● ● B	○	○
Electric Cabinet Light		○	○
Remote MPG		○	○
Work Counter	Digital	○	○
Total Counter	Digital	○	○
Tool Counter	Digital	○	○
Multi Tool Counter	6EA	○	○
	9EA	○	○
Electric Circuit Breaker		○	○
AVR (Auto Voltage Regulator)		☆	☆
Transformer	30kVA	○/-	○/-
	35kVA	-/○	-/○
Auto Power Off		○	○
Measurement			
Manual Q-Setter (Basic)		○	○
Manual Q-Setter (Renishaw)		○	○
Automatic Q-Setter (Renishaw)		○	○
Work Close Confirmation Device (Only for Special Chuck)	TACO	○	○
	SMC	○	○
Work Setter		○	○
Linear Scale	X/Y/Z axis	○	○
Coolant Level Sensor (Only for Chip Conveyor)		☆	☆
Environment			
Air Conditioner		○	○
Dehumidifier		○	○
Oil Mist Collector		☆	☆
Oil Skimmer (Only for Chip Conveyor)		○	○
MQL (Minimal Quantity Lubrication)		☆	☆
Fixture & Automation			
Auto Door		○	○
Auto Shutter (Only for Automatic System)		☆	☆
Sub Operation Pannel		☆	☆
Bar Feeder Interface		○	○
Bar Feeder (FEDEK)		☆	☆
Work Pusher (Spring Type)		○	○
Work Ejector (Pneumatic Type)		☆	☆
Extra M-Code 4ea		○	○
Automation Interface		☆	☆
I/O Extension (IN & OUT)	16 Contact	○	○
	32 Contact	○	○
Parts Catcher	Main SP.	○	○
	Sub SP.	-/○	-/○
Turret Work Pusher (For Automation)		☆	☆
Parts Conveyor (Required Main Parts Catcher)		☆	☆
Semi Automation System		☆	☆
Hyd. Device			
Standard Hyd. Cylinder	Hollow	●	●
Standard Hyd. Unit	35bar(507.6psi) / 30 ℓ (7.9gal)	●	●
S/W			
Conversational program	SmartGuide-i	●	●
	HW-DPRO	○	○
Thermal Displacement Compensation (HW-TDC)		○	○
Tool Monitoring (HW-TM)		○	○
Machine Guidance (HW-MCG)		●	●
Energy Saving System (HW-ESS)		●	●
DNC software (HW-eDNC)		○	○
Machine Monitoring System (HW-MMS)		○	○
Thermal Displacement Compensation Device		○	-
Premium Tool Operation		●	●
Manual Viewer		●	●
Scheduling		●	●
Operation Memo		●	●
ETC			
Tool Box		●	●
Customized Color	Need Munsell No.	☆	☆
CAD & CAM		☆	☆

❖ Thermal Displacement Compensation device is recommended, when more than 6 bar of high pressure coolant is applied, for the high quality machining.

Specifications are subject to change without notice for improvement.

SPECIFICATIONS

Standard & Optional

● : Standard ○ : Option ☆ : Prior Consultation - : Non Applicable

Spindle		HD3100YA/SYA	HD3100Y/SY
Main Spindle	8"	●	-
Hollow Chuck 3 Jaw	10"	-	●
Main Spindle	8"	-	-
Solid Chuck 3 Jaw	10"	-	-
Sub SP. Hollow Chuck 3 Jaw	5"	-/●	-/●
Sub Sp. Solid Chuck 3 Jaw	5"	-	-
Standard Soft Jaw (1set)		●	●
Chuck Clamp Foot Switch		●	●
2 Steps Hyd. Pressure Device		○	○
Spindle Inside Stopper		☆	☆
Cs-Axis (0.001")		●	●
Chuck Open/Close Confirmation Device		●	●
2 Steps Chuck Foot Switch		○	○
Sub Spindle Foot Switch		-/●	-/●
Turret			
Tool Holder		●	●
Mill Turret	BMT	●	●
	12 Tool	●	●
	24 Tool	-	-
Straight Milling Head (Axial)	Collet Type, 2ea	●	●
Angular Milling Head (Radial)	Collet Type, 2ea	●	●
Straight Milling Head (Axial)	Adapter Type	○	○
Angular Milling Head (Radial)	Adapter Type	○	○
Boring Sleeve		●	●
Drill Socket		○	○
U-Drill Holder		●	●
U-Drill Holder Sleeve		●	●
Angle Head		☆	☆
Tail Stock & Steady Rest			
Quill Tail Stock	MT#4	-	-
	MT#5	●/-	●/-
Built-in Tail Stock		○/-	○/-
Programmable Tail Stock		○/-	○/-
Manual Hyd. Steady Rest		-	-
Standard Live Center		●/-	●/-
High Precision Live Center		☆/-	☆/-
2 Steps Tail Stock Pressure System		☆/-	☆/-
Quill Forward/Reverse Confirmation Device		○/-	○/-
Tail Stock Foot Switch		○/-	○/-
Coolant & Air Blow			
Standard Coolant (Nozzle)		●	●
Chuck Coolant (Upper Chuck)		○	○
Gun Coolant		○	○
Through Spindle Coolant (Only for Special Chuck)		☆	☆
Turnmill Through Coolant		-	-
Chuck Air Blow	Main SP.	○	○
	Sub SP.	-/○	-/○
Tail Stock Air Blow (Upper Tail Stock)		-	○
Turret Air Blow		☆	☆
Air Gun		○	○
Through Spindle Air Blow (Only for Special Chuck)		-	-
High Pressure Coolant	0.5Bar	●	●
	6Bar	○	○
	20Bar	○	○
	70Bar	○	○
Power Coolant System (For Automation)		☆	☆
Coolant Chiller (When selecting Sub Tank Type, Chip Conveyor)		-	-
Chip Disposal			
Coolant Tank	Right	●	●
	Rear	☆	☆
Chip Conveyor (Hinge/Scraper)	Front (Right)	○	○
	Rear (Rear)	☆	☆
Special Chip Conveyor (Drum Filter)		-	-
Chip Wagon	Standard (180 ℓ [47.5 gal])	○	○
	Swing (200 ℓ [52.8 gal])	○	○
	Large Size (330 ℓ [87.2 gal])	○	○
	Customized	☆	☆
Safety Device			
Front Door Interlock		●	●
Total Splash Guard		●	●
Chuck Hydraulic Pressure Maintenance Interlock		☆	☆

Electric Device		HD3100YA/SYA	HD3100Y/SY
Call Light	1Color : ●	●	●
Call Light & Buzzer	3Color : ●●●B	○	○
Electric Cabinet Light		○	○
Remote MPG		○	○
Work Counter	Digital	○	○
Total Counter	Digital	○	○
Tool Counter	Digital	○	○
Multi Tool Counter	6EA	○	○
	9EA	○	○
Electric Circuit Breaker		○	○
AVR (Auto Voltage Regulator)		☆	☆
Transformer	30kVA	○/-	○/-
	40kVA	-/○	-/○
Auto Power Off		○	○
Measurement			
Manual Q-Setter (Basic)		○	○
Manual Q-Setter (Renishaw)		○	○
Automatic Q-Setter (Renishaw)		○	○
Work Close Confirmation Device (Only for Special Chuck)	TACO	☆	☆
	SMC	☆	☆
Work Setter		☆	☆
Linear Scale	X/Y/Z axis	☆	☆
Coolant Level Sensor (Only for Chip Conveyor)		☆	☆
Environment			
Air Conditioner		○	○
Dehumidifier		○	○
Oil Mist Collector		☆	☆
Oil Skimmer (Only for Chip Conveyor)		○	○
MQL (Minimal Quantity Lubrication)		☆	☆
Fixture & Automation			
Auto Door		○	○
Auto Shutter (Only for Automatic System)		☆	☆
Sub Operation Pannel		☆	☆
Bar Feeder Interface		○	○
Bar Feeder (FEDEK)		☆	☆
Work Pusher (Spring Type)		○	○
Work Ejector (Pneumatic Type)		☆	☆
Extra M-Code 4ea		○	○
Automation Interface		☆	☆
I/O Extension (IN & OUT)	16 Contact	○	○
	32 Contact	○	○
Parts Catcher	Main SP.	○	○
	Sub SP.	-/○	-/○
Turret Work Pusher (For Automation)		☆	☆
Parts Conveyor (Required Main Parts Catcher)		☆	☆
Semi Automation System		☆	☆
Hyd. Device			
Standard Hyd. Cylinder	Hollow	●	●
Standard Hyd. Unit	35bar(507.6psi) / 30 ℓ (7.9gal)	●	●
S/W			
Conversational program	SmartGuide-i	●	●
	HW-DPRO	○	○
Thermal Displacement Compensation (HW-TDC)		○	○
Tool Monitoring (HW-TM)		○	○
Machine Guidance (HW-MCG)		●	●
Energy Saving System (HW-ESS)		●	●
DNIC software (HW-eDNIC)		○	○
Machine Monitoring System (HW-MMS)		○	○
Thermal Displacement Compensation Device		○	-
Premium Tool Operation		●	●
Manual Viewer		●	●
Scheduling		●	●
Operation Memo		●	●
ETC			
Tool Box		●	●
Customized Color	Need Munsell No.	☆	☆
CAD & CAM		☆	☆

◆ Thermal Displacement Compensation device is recommended, when more than 6 bar of high pressure coolant is applied, for the high quality machining.

Specifications are subject to change without notice for improvement.

SPECIFICATIONS

Spindle Output/Torque Diagram

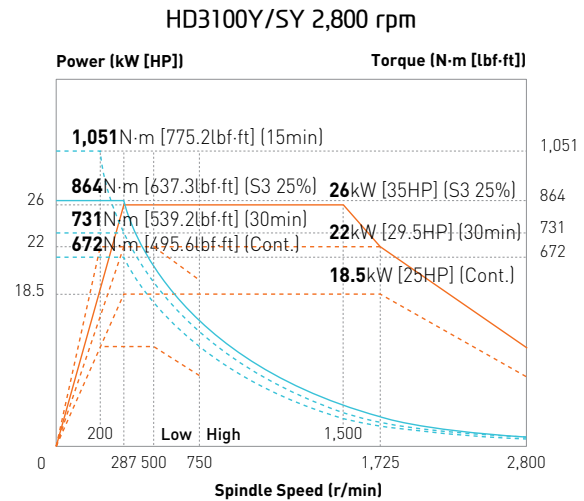
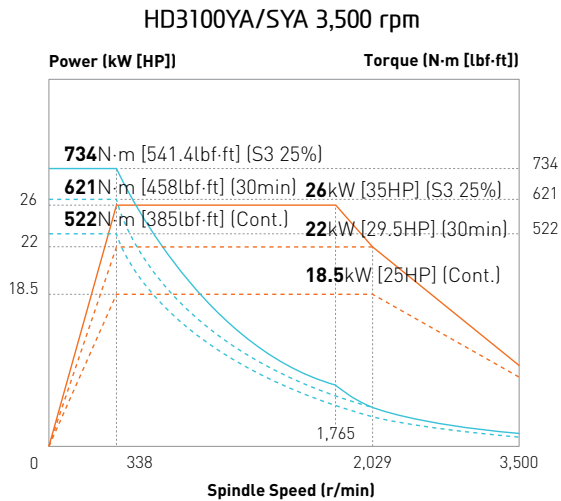
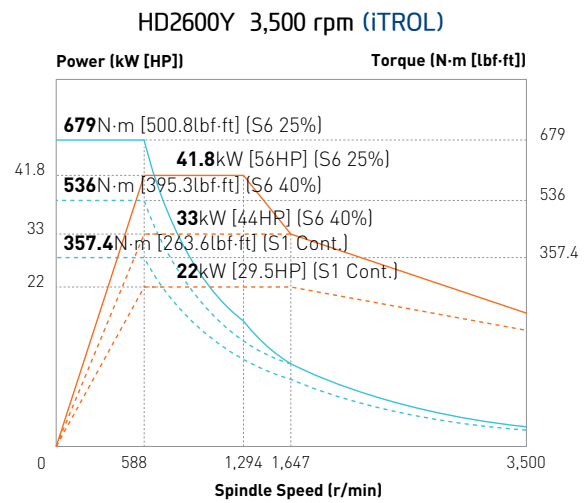
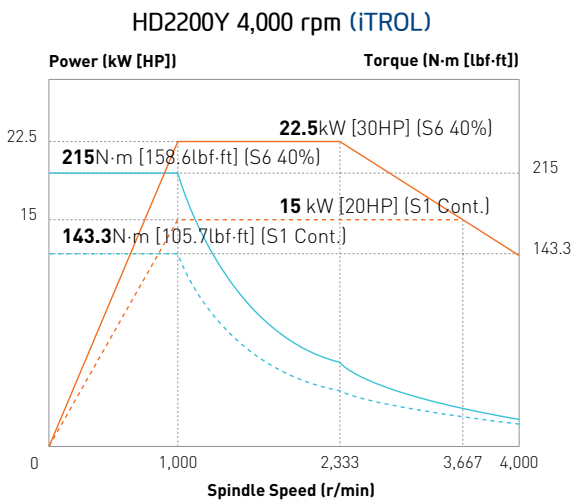
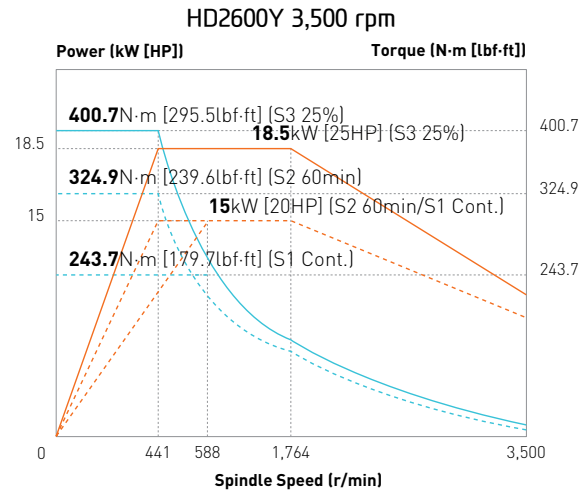
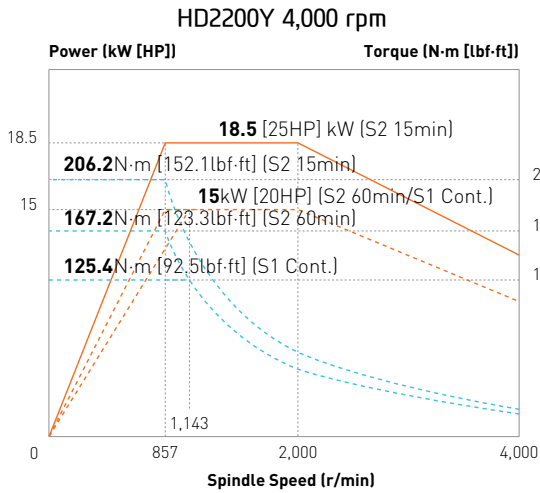

SPECIFICATIONS

Spindle Output/Torque Diagram

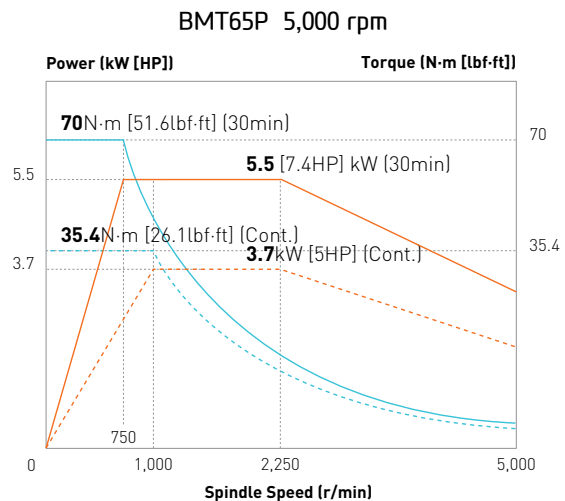
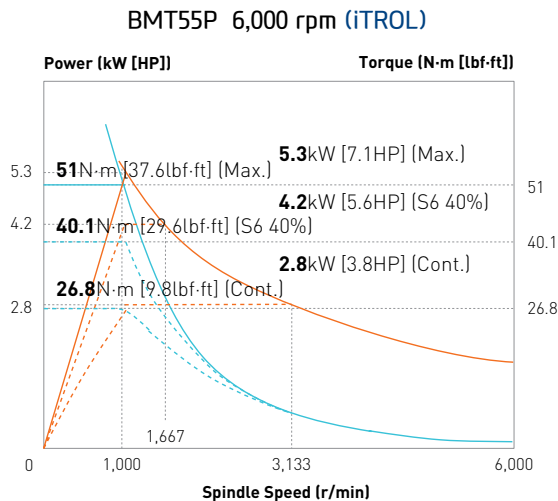
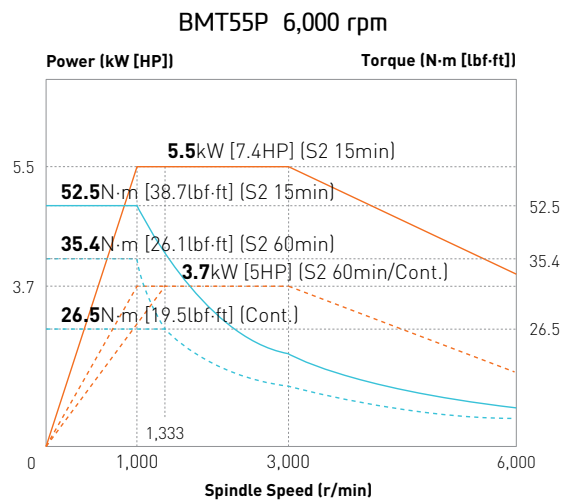
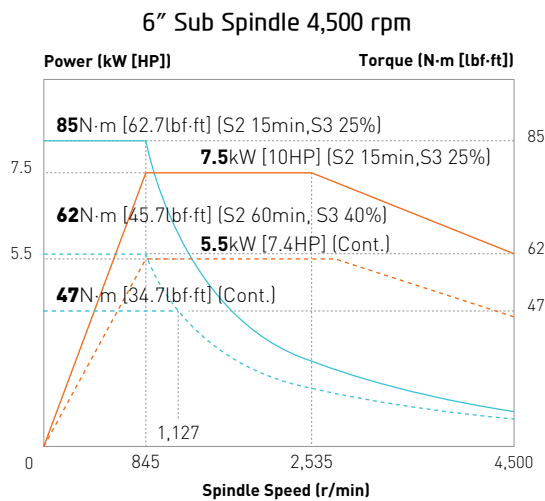
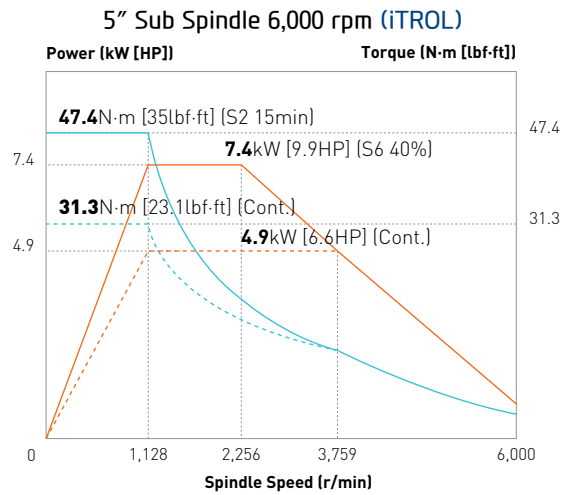
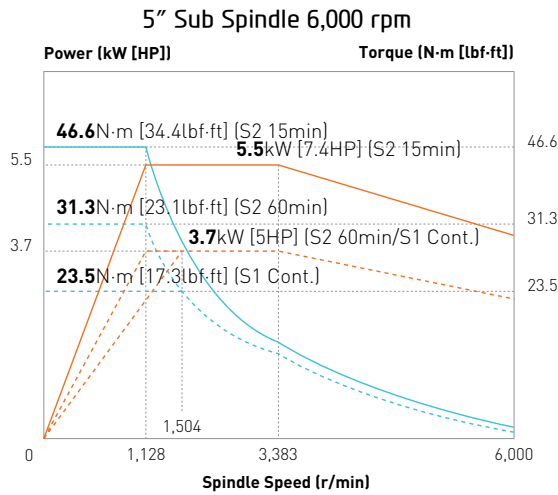

SPECIFICATIONS

External Dimensions

unit : mm(in)

HD2200Y/SY
HD2600Y/SY

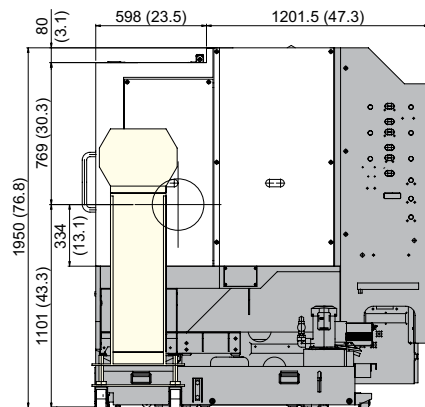
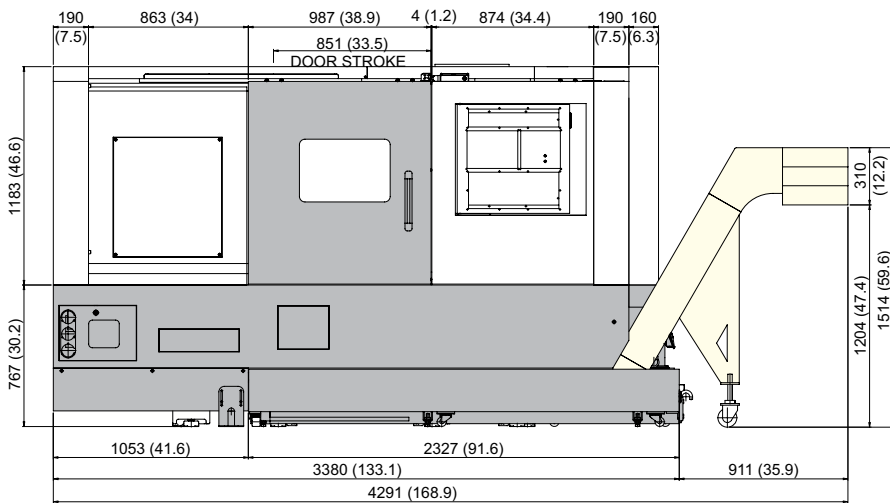
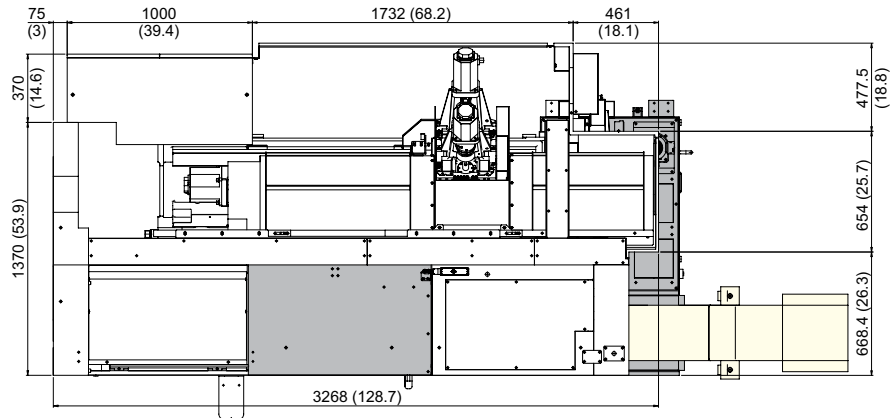

SPECIFICATIONS

External Dimensions

unit : mm(in)

HD3100YA/SYA
HD3100Y/SY

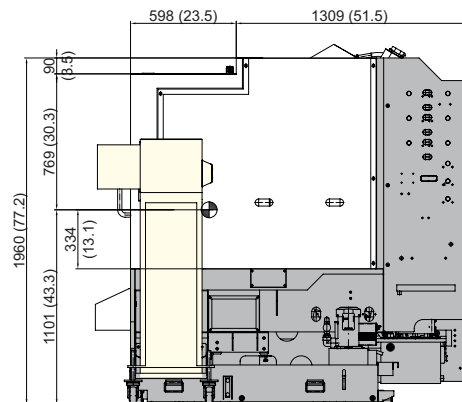
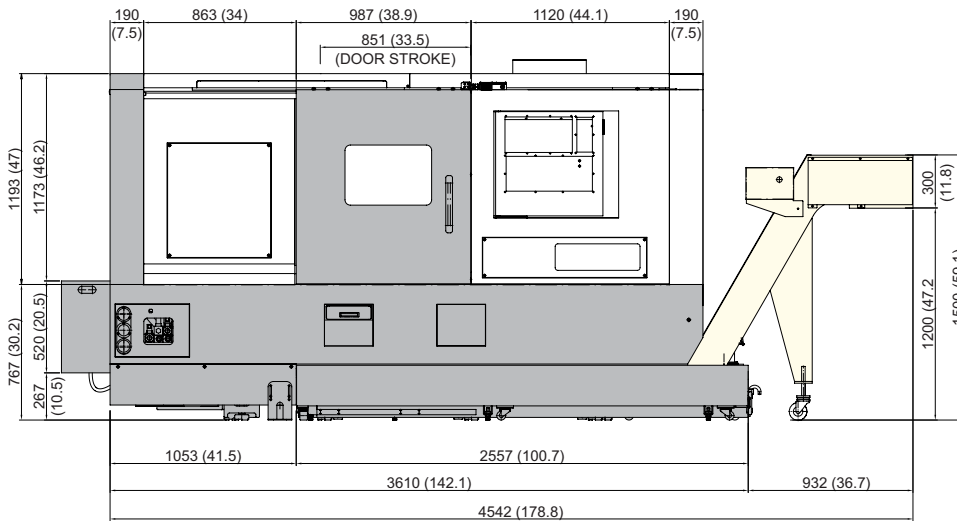
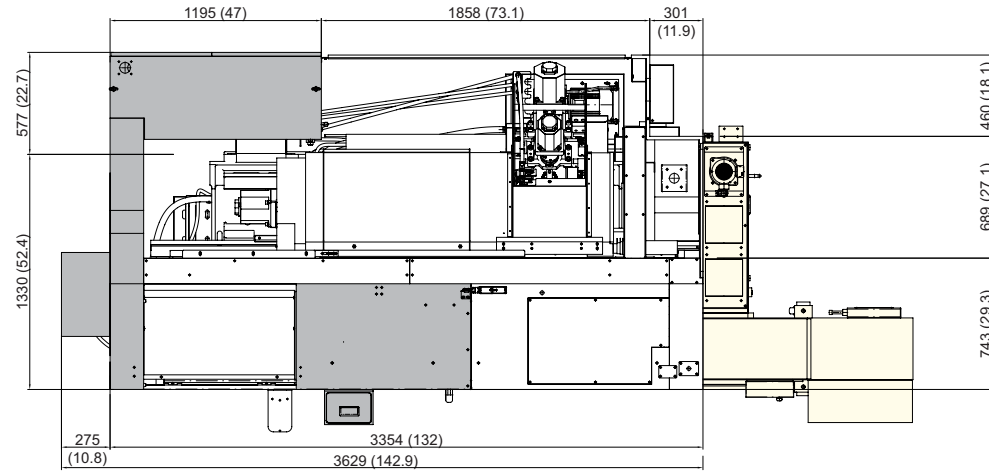

SPECIFICATIONS

Interference

unit : mm(in)

HD2200Y
HD2600Y

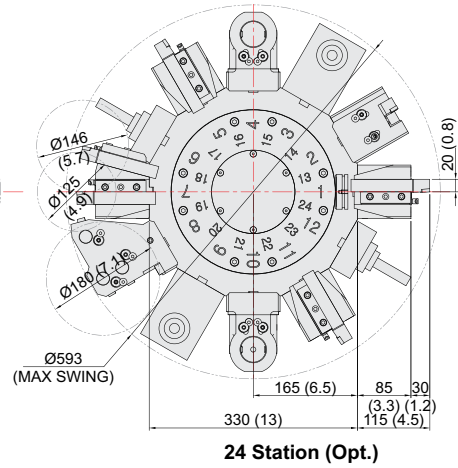
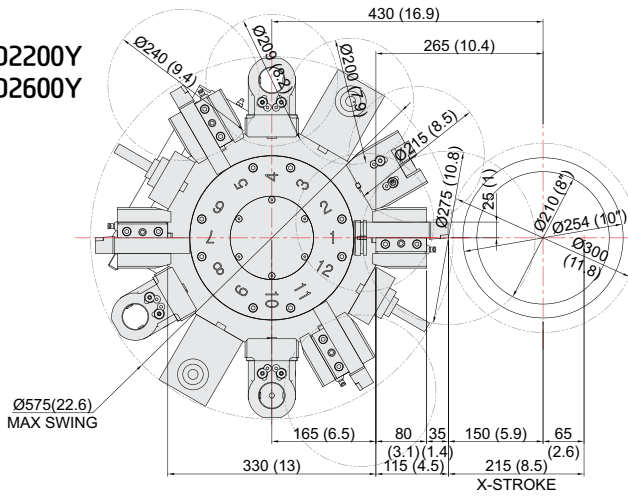

24 Station (Opt.)

HD2200SY
HD2600SY

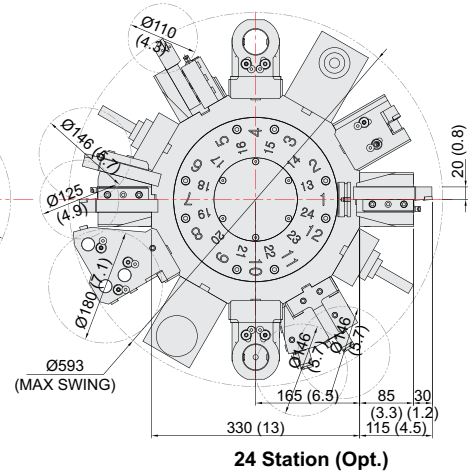
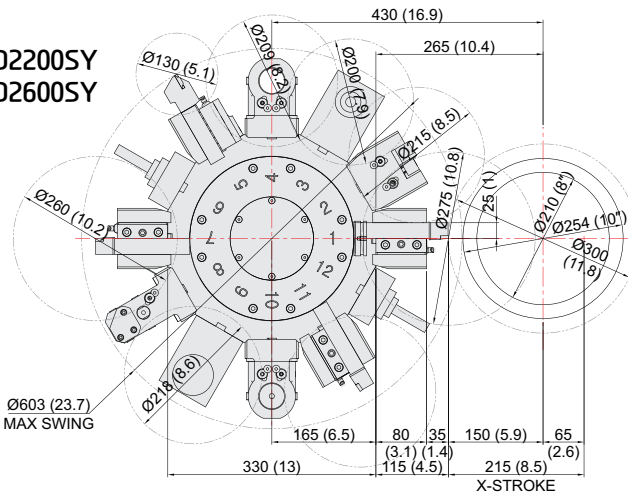

24 Station (Opt.)

Y-axis Travel Range

unit : mm(in)

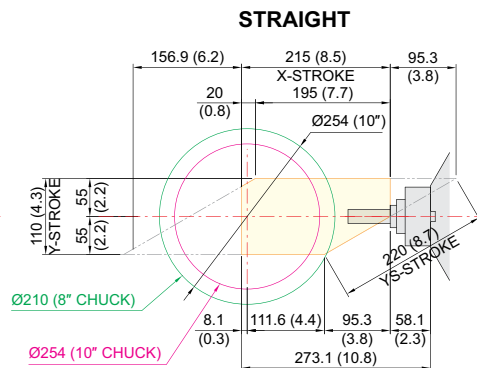
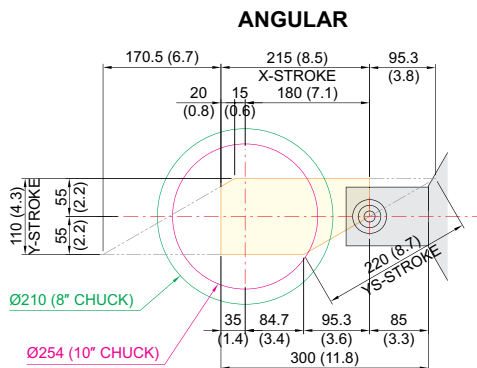

SPECIFICATIONS

Interference

unit : mm(in)

HD3100SYA
HD3100SY

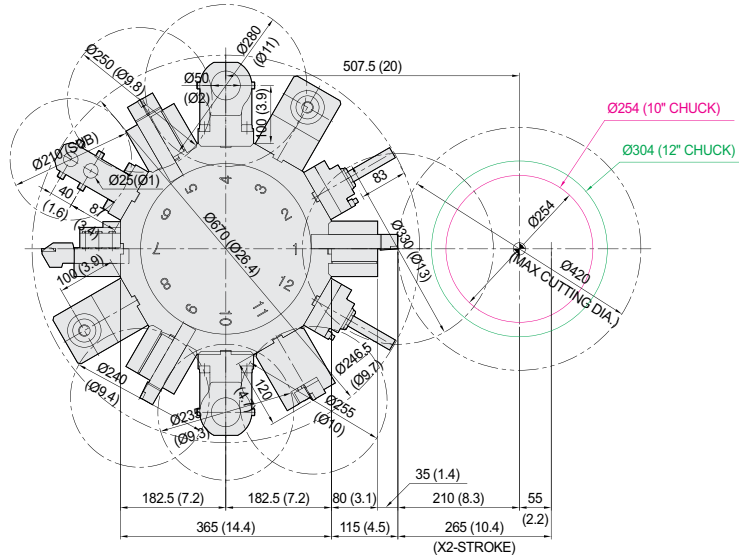

HD3100YA
HD3100Y

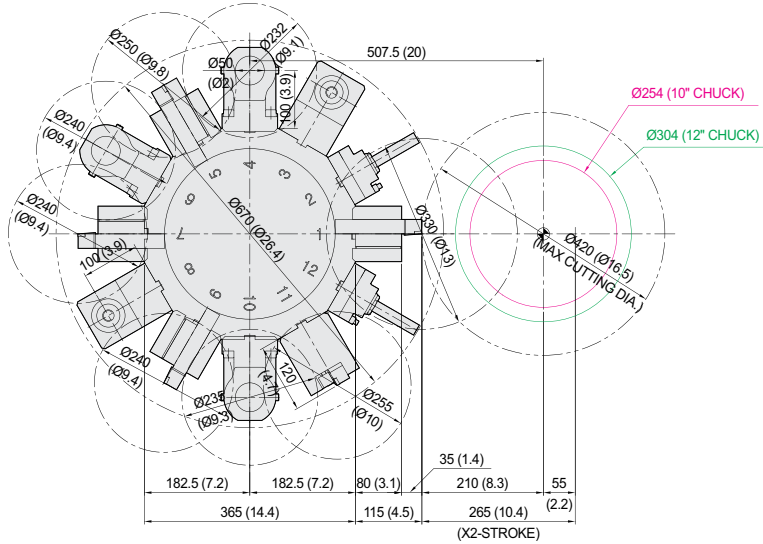

Y-axis Travel Range

unit : mm(in)

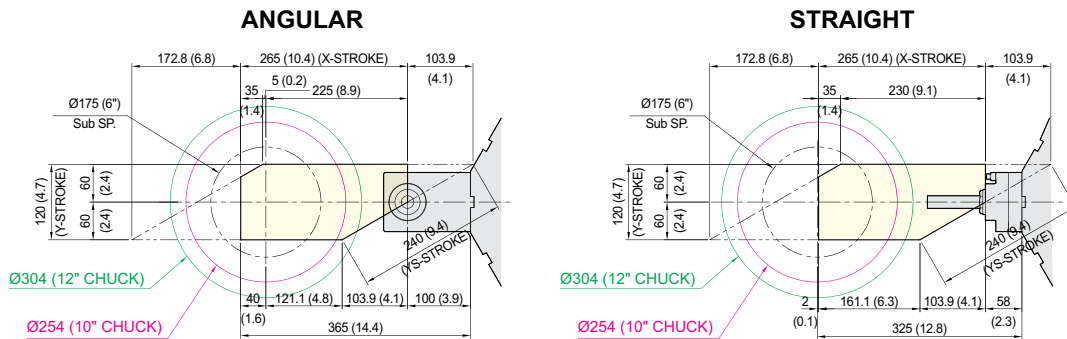

SPECIFICATIONS

Tooling System

unit : mm(in)

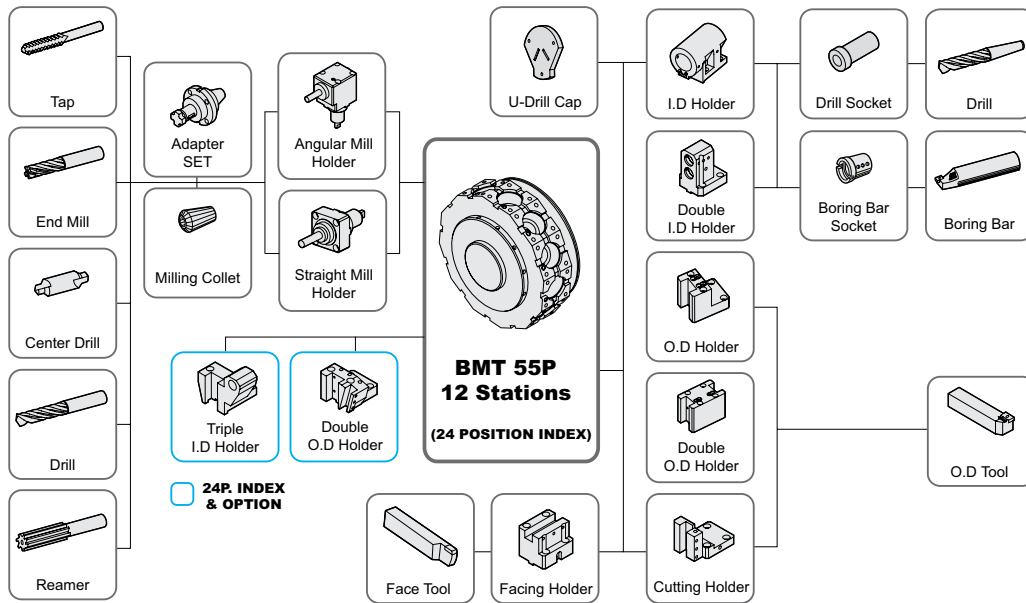

HD2200Y | HD2600Y Tooling Parts Detail

ITEM			Y Type (12P)		Y Type (24P : Opt.)		
			mm Unit	inch Unit	mm Unit	inch Unit	
Turning Holder	O.D Holder	Right/Left	4	4	3	3	
		Double	-	-	-	-	
		Double (24P, Main)	-	-	1	1	
		Double (24P, Sub)	-	-	-	-	
	Facing Holder		1	1	1	1	
	Cutting Holder		-	-	-		
Boring Holder	I.D Holder	Single	3	3	2	2	
		Double	-	-	-	-	
		Triple	-	-	1	1	
	U-Drill Holder	Cap	1	1	1	1	
Driven Holder	Straight Mill Holder	Standard	2	2	2	2	
	Angular Mill Holder	Standard	2	2	2	2	
Socket	Boring	Ø10 (Ø3/8")	1	1	1	1	
		Ø12 (Ø1/2")	1	1	1	1	
		Ø16 (Ø5/8")	1	1	1	1	
		Ø20 (Ø3/4")	1	1	1	1	
		Ø25 (Ø1")	1	1	1	1	
		Ø32 (Ø1 1/4")	1	1	1	1	
	Sub Boring	Ø8 (5/16")	-	-	-	-	
		Ø12 (1/2")	-	-	-	-	
		Ø16 (5/8")	-	-	-	-	
	Drill	MT 2	-	-	-	-	
		MT 3	-	-	-	-	
		MT 4	-	-	-	-	
		ER Collet		1 Set	1 Set	1 Set	1 Set
		Adapter Set		Opt.	Opt.	Opt.	Opt.

SPECIFICATIONS

Tooling System

unit : mm(in)

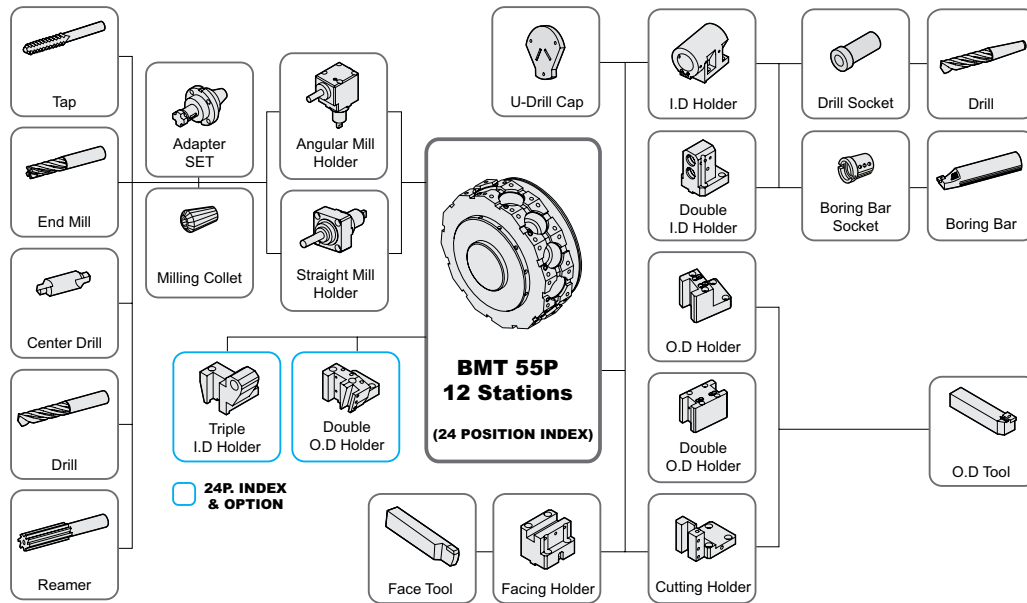

HD2200SY | HD2600SY Tooling Parts Detail

ITEM			SY Type (12P)		SY Type (24P : Opt.)	
			mm Unit	inch Unit	mm Unit	inch Unit
Turning Holder	O.D Holder	Right/Left	2	2	2	2
		Double	1	1	-	-
		Double (24P, Main)	-	-	1	1
		Double (24P, Sub)	-	-	1	1
	Facing Holder	1	1	1	1	
Cutting Holder	1	1	1	1		
Boring Holder	I.D Holder	Single	2	2	2	2
		Double	1	1	-	-
		Triple	-	-	1	1
	U-Drill Holder	Cap	1	1	1	1
Driven Holder	Straight Mill Holder	Standard	2	2	2	2
	Angular Mill Holder	Standard	2	2	2	2
Socket	Boring	Ø10 (Ø3/8")	1	1	1	1
		Ø12 (Ø1/2")	1	1	1	1
		Ø16 (Ø5/8")	1	1	1	1
		Ø20 (Ø3/4")	1	1	1	1
		Ø25 (Ø1")	1	1	1	1
		Ø32 (Ø1 1/4")	1	1	1	1
		Sub Boring	Ø8 (5/16")	1	1	1
	Sub Boring	Ø12 (1/2")	1	1	1	1
		Ø16 (5/8")	1	1	1	1
		Drill	MT 2	-	-	-
	Drill	MT 3	-	-	-	-
		MT 4	-	-	-	-
		ER Collet	1 Set	1 Set	1 Set	1 Set
	Adapter Set	Opt.	Opt.	Opt.	Opt.	

Specifications are subject to change without notice for improvement.

SPECIFICATIONS

Tooling System

unit : mm(in)

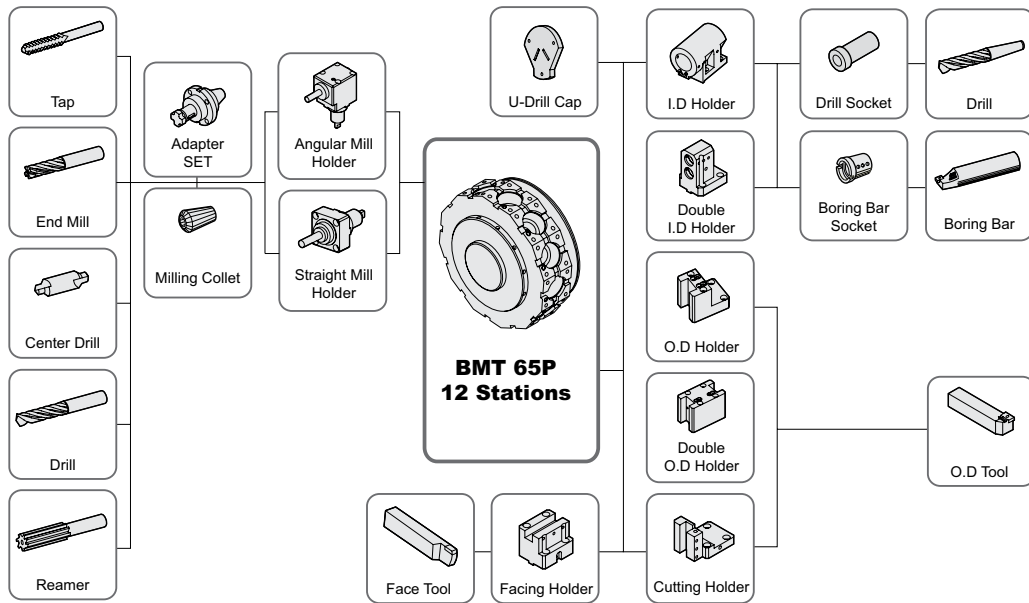

HD3100YA/SYA | HD3100Y/SY Tooling Parts Detail

ITEM			Y Type (12P)		SY Type (12P)	
			mm Unit	inch Unit	mm Unit	inch Unit
Turning Holder	O.D Holder	Right/Left	4	4	2	2
		Double	-	-	1	1
		Double (24P, Rear)	-	-	-	-
		Double (24P)	-	-	-	-
	Facing Holder		1	1	1	1
	Cutting Holder		-	-	1	1
Boring Holder	I.D Holder	Single	3	3	2	2
		Double	-	-	1	1
		Triple	-	-	-	-
	U-Drill Holder	Cap	1	1	1	1
Driven Holder	Straight Mill Holder	Standard	2	2	2	2
	Angular Mill Holder	Standard	2	2	2	2
Socket	Boring	Ø12 (Ø3/8")	1	1	1	1
		Ø16 (Ø5/8")	1	1	1	1
		Ø20 (Ø3/4")	1	1	1	1
		Ø25 (Ø1")	1	1	1	1
		Ø32 (Ø1 1/4")	1	1	1	1
		Ø40 (Ø1 1/2")	1	1	1	1
	Sub Boring	Ø12 (Ø3/8")	-	-	1	1
		Ø16 (Ø5/8")	-	-	1	1
		Ø20 (Ø3/4")	-	-	1	1
	Drill	MT 2	Opt.	Opt.	Opt.	Opt.
		MT 3	Opt.	Opt.	Opt.	Opt.
		MT 4	Opt.	Opt.	Opt.	Opt.
		ER Collet		1 Set	1 Set	1 Set
	Adapter Set		Opt.	Opt.	Opt.	Opt.

SPECIFICATIONS

Tooling Travel Range

unit : mm(in)

HD2200Y

O.D. Tool holder

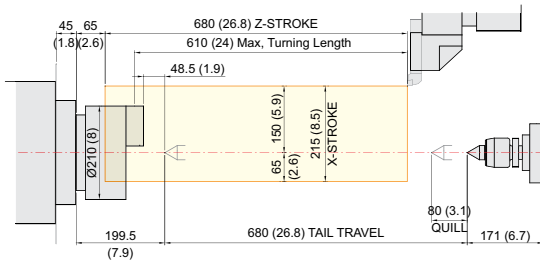

I.D. Tool holder

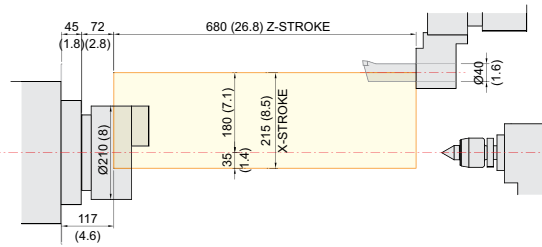

Straight Mill Holder

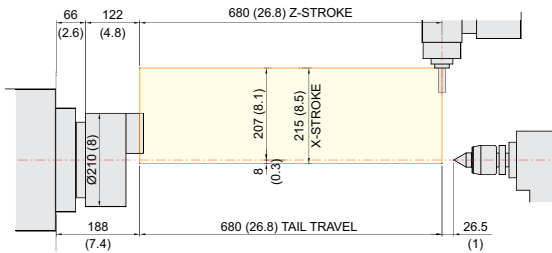

Angular Mill Holder

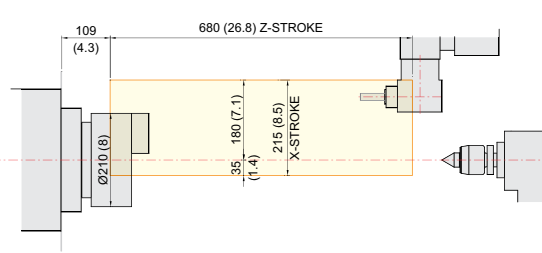

Face Tool holder

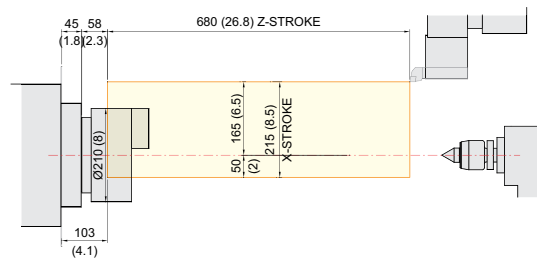

SPECIFICATIONS

Tooling Travel Range

unit : mm(in)

HD2200SY

O.D. Tool holder

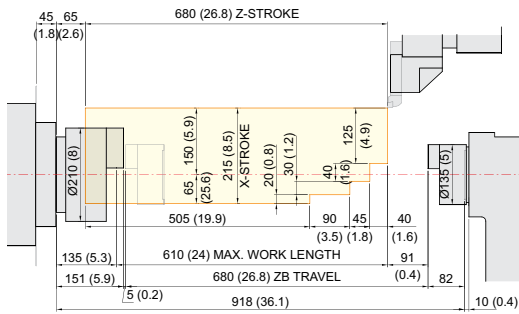

I.D. Tool holder

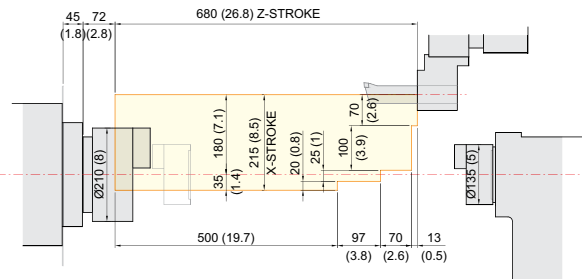

Straight Mill Holder

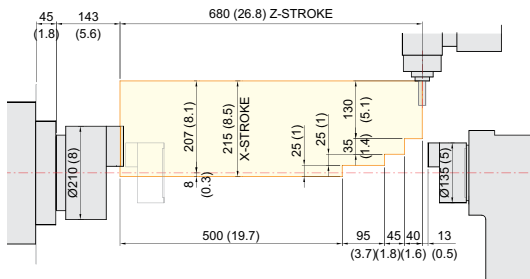

Angular Mill Holder

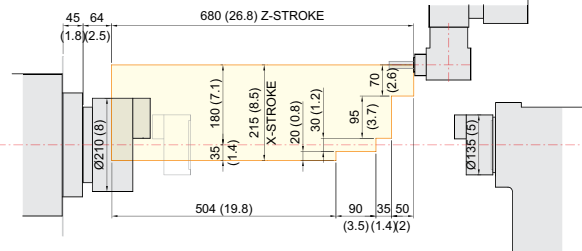

Face Tool holder

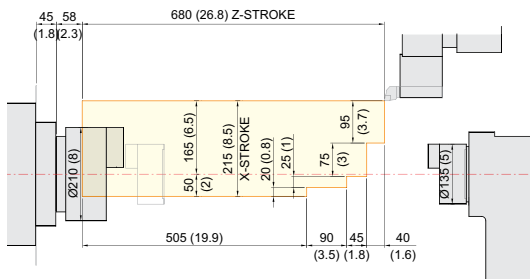

Sub Sp. Angular Mill Holder

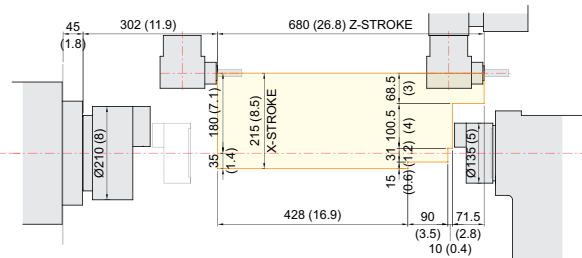

SPECIFICATIONS

Tooling Travel Range

unit : mm(in)

HD2600Y

O.D. Tool holder

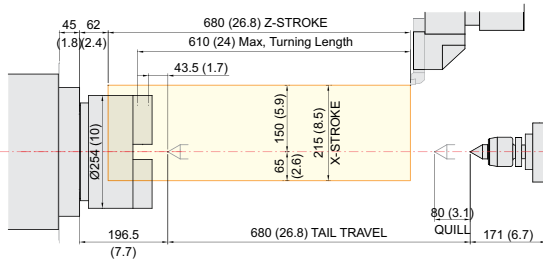

I.D. Tool holder

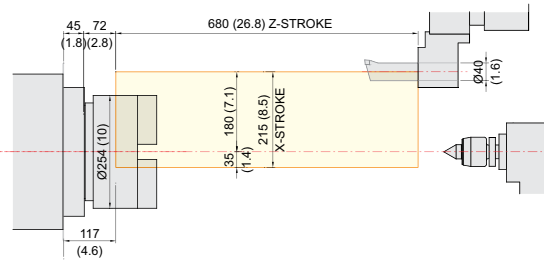

Straight Mill Holder

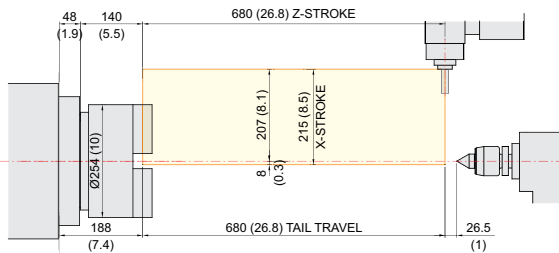

Angular Mill Holder

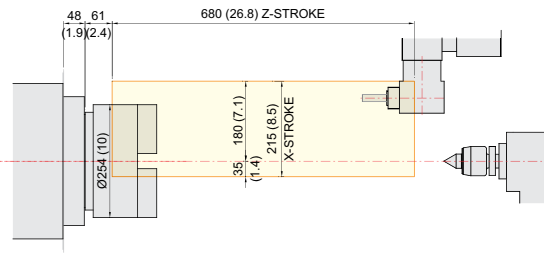

Face Tool holder

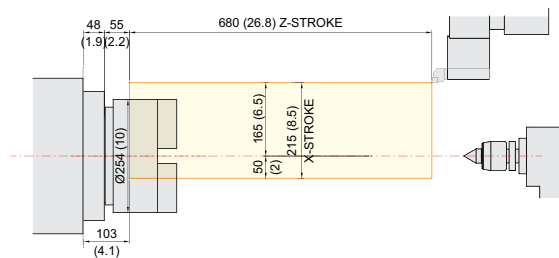

SPECIFICATIONS

Tooling Travel Range

unit : mm(in)

HD2600SY

O.D. Tool holder

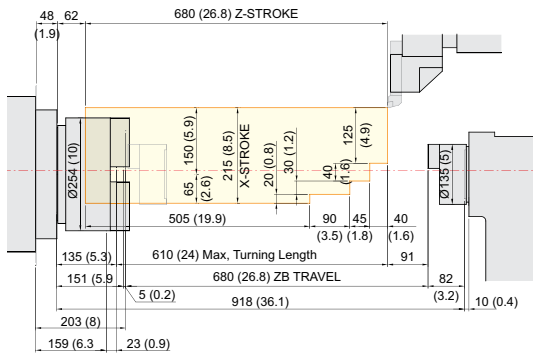

I.D. Tool holder

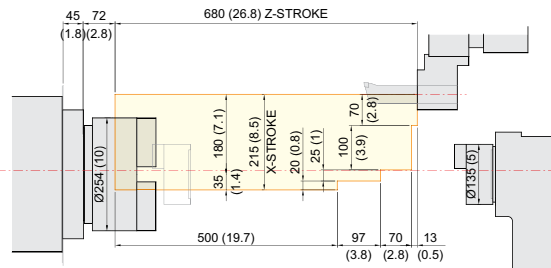

Straight Mill Holder

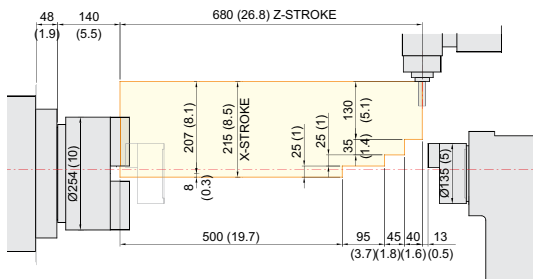

Angular Mill Holder

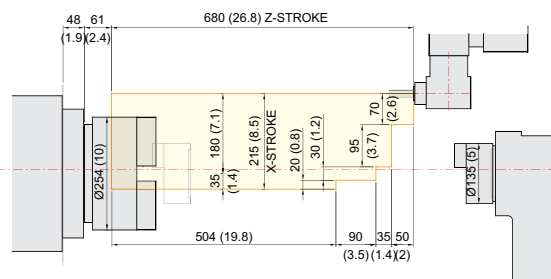

Face Tool holder

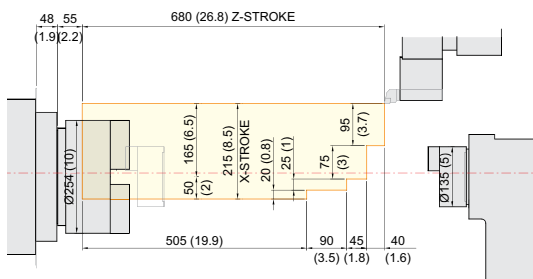

Sub Sp. Angular Mill Holder

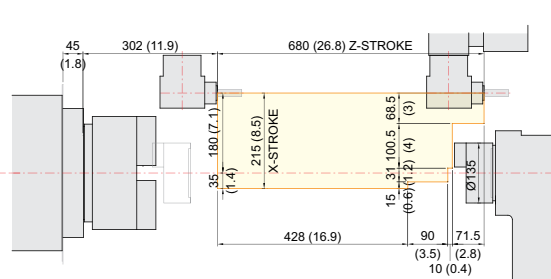

SPECIFICATIONS

Tooling Travel Range

unit : mm(in)

HD3100YA

O.D. Tool holder

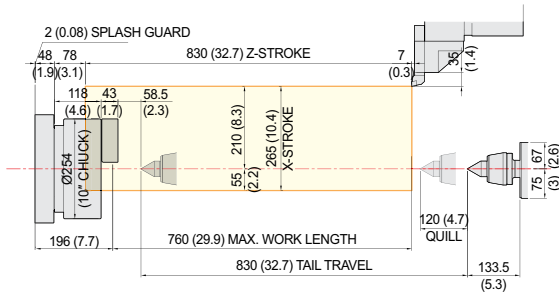

I.D. Tool holder

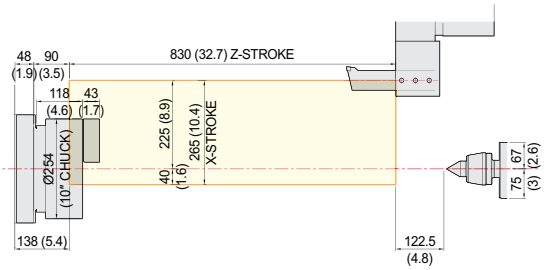

Axial driven Tool holder

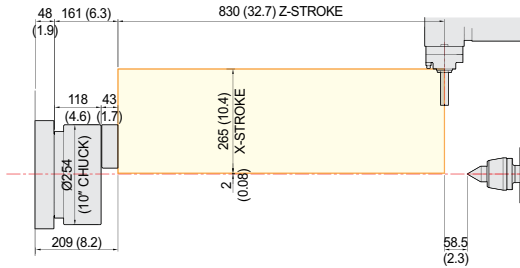

Angular driven Tool holder

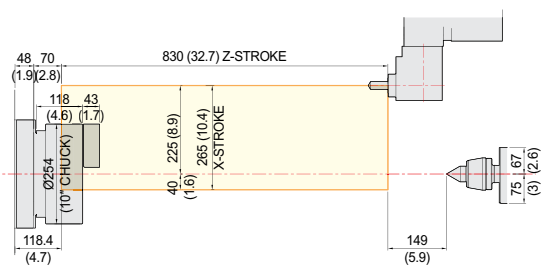

Face Tool holder

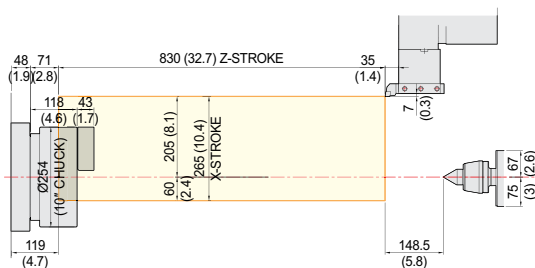

SPECIFICATIONS

Tooling Travel Range

unit : mm(in)

HD3100SYA

O.D. Tool holder

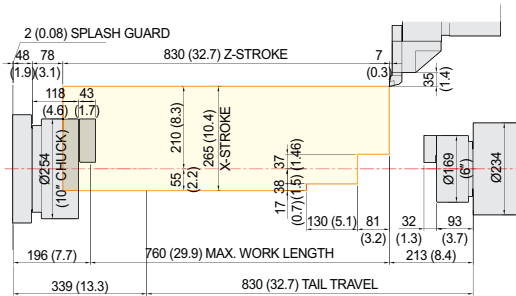

I.D. Tool holder

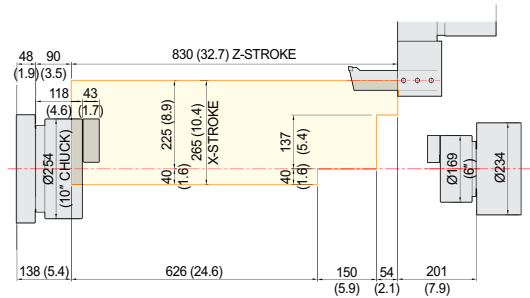

Axial driven Tool holder

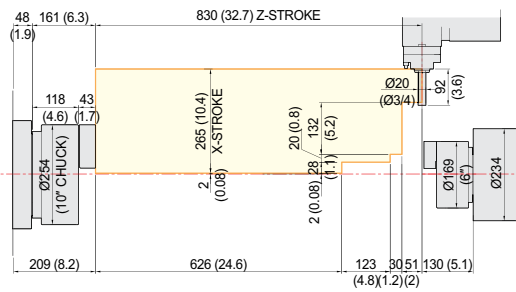

Angular driven Tool holder

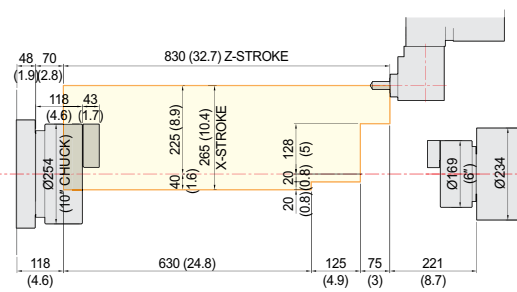

Face Tool holder

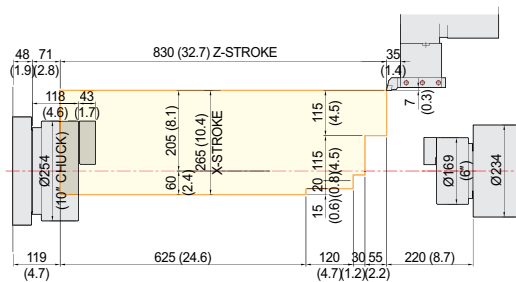

SPECIFICATIONS

Tooling Travel Range

unit : mm(in)

HD3100Y

O.D. Tool holder

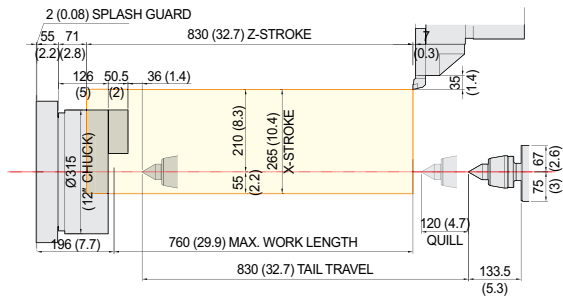

I.D. Tool holder

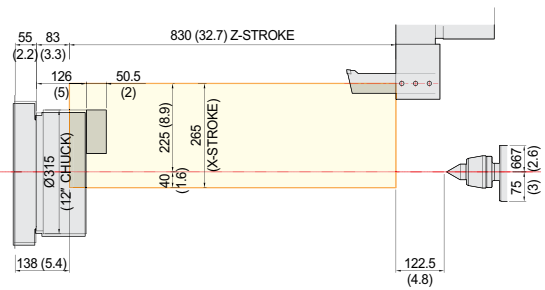

Axial driven Tool holder

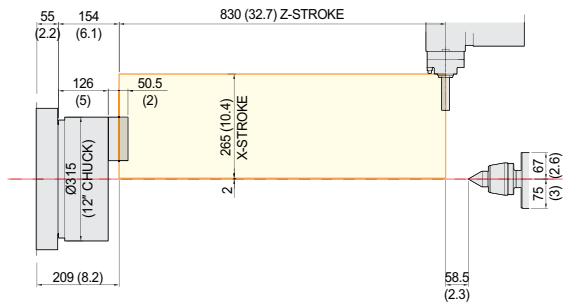

Angular driven Tool holder

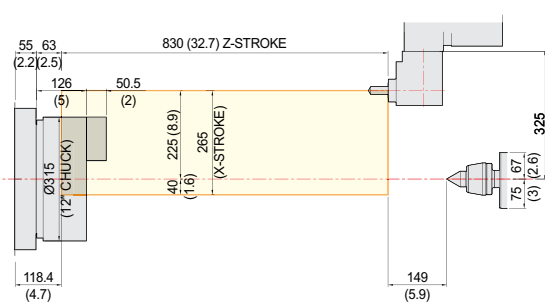

Face Tool holder

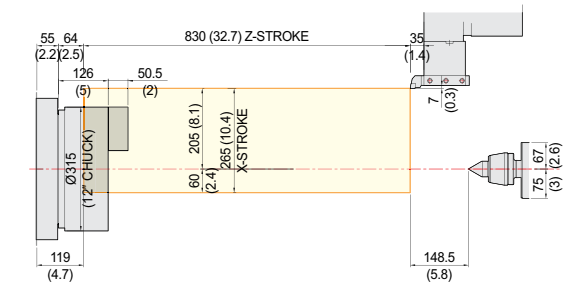

SPECIFICATIONS

Tooling Travel Range

unit : mm(in)

HD3100SY

O.D. Tool holder

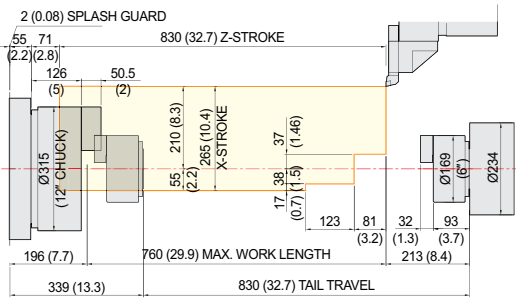

I.D. Tool holder

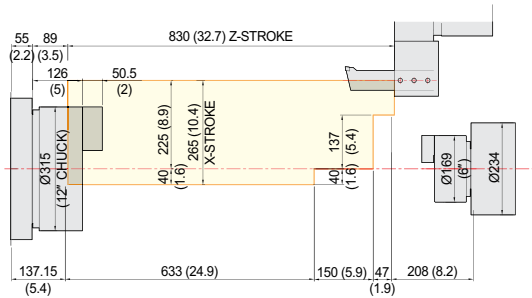

Axial driven Tool holder

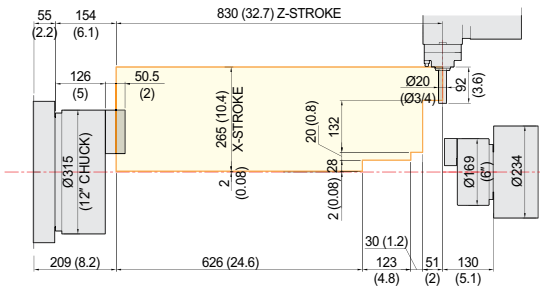

Angular driven Tool holder

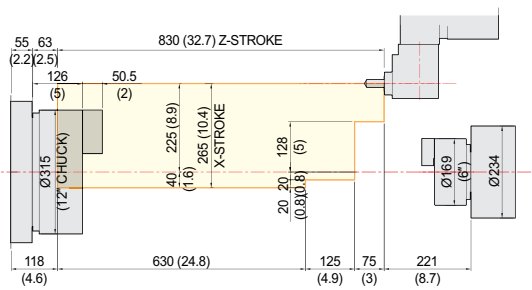

Face Tool holder

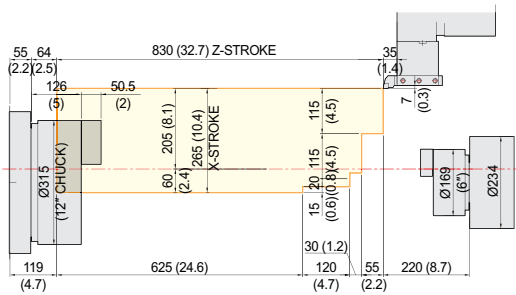

SPECIFICATIONS

Specifications

[] : Option

ITEM			HD2200Y	HD2200SY	HD2600Y	HD2600SY	
CAPACITY	Swing Over the Bed	mm(in)	Ø820 (Ø32.3")				
	Swing Over the Carriage	mm(in)	Ø650 (Ø25.6")				
	Max. Turning Dia.	mm(in)	Ø300 (Ø11.8")				
	Max. Turning Length	mm(in)	610 (24")				
	Bar Capacity	Main	mm(in)	Ø65 (Ø2.6")		Ø81 (Ø3.2")	
Sub		mm(in)	-	Ø32 (Ø1.3")	-	Ø32 (Ø1.3")	
SPINDLE	Chuck Size	Main	8"		10"		
		Sub	-	5"	-	5"	
	Spindle Bore	Main	Ø76 (Ø3")		Ø91 (Ø3.6")		
		Sub	-	Ø43 (Ø1.7")	-	Ø43 (Ø1.7")	
	Spindle Speed (rpm)	Main	4,000 [4,000]		3,500 [3,500]		
		Sub	-	6,000 [6,000]	-	6,000 [6,000]	
	Motor (Max/Cont.)	Main	kW(HP)	18.5/15 (25/20) [22.5/15 (30/20)]	18.5/15 (25/20) [41.8/22 (56/29.5)]		
		Sub	kW(HP)	-	5.5/3.7 (7.4/5) [7.4/4.9 (9.9/6.6)]	-	5.5/3.7 (7.4/5) [7.4/4.9 (9.9/6.6)]
	Torque (Max/Cont.)	Main	N·m	206.2/125.4 [215/143.3]		400.7/243.7 [679/357.4]	
		Sub	N·m	-	46.6/23.5 [47/31.1]	-	46.6/23.5 [47/31.1]
	Spindle Type	Main	-	BELT			
		Sub	-	-	BELT	-	BELT
	Spindle Nose	Main	-	A2-6		A2-8	
		Sub	mm(in)	-	FLAT Ø110 (4.3")	-	FLAT Ø110 (4.3")
C-axis Indexing	deg	0.001°					
FEED	Travel	X/Y	215/110 {±55} (8.5"/4.3" {±2.17"})				
		Z/ZB	680 (26.8")	680/680 (26.8"/26.8")	680 (26.8")	680/680 (26.8"/26.8")	
	Rapid Traverse Rate	X/Y	24/10 (944/394)				
		Z/ZB	30 (1,181)	30/24 (1,181/994)	30 (1,181)	30/24 (1,181/994)	
Slide Type	-	BOX GUIDE					
TURRET	No. of Tools	ea	12 [24]				
	Tool Size	O.D/I.D	□25 (□1") [24 Tool : □20 (□3/4") / Ø40 (Ø1.6")				
	Indexing Time	sec/step	0.2				
	Y-Axis Type	-	WEDGE TYPE				
LIVE TOOL	Milling Tool Speed (rpm)	r/min	6,000 [6,000]				
	Motor (Max/Cont.)	kW(HP)	5.5/3.7 (7.4/5) [5.3/2.8 (7/4)]				
	Torque (Max/Cont.)	N·m	52.5/26.5 [51/26.8]				
	Collet Size	mm(in)	Ø16 (Ø5/8") (ER25)				
	Type	-	BMT55P				
TAIL STOCK	Taper	-	MT#4	-	MT#4	-	
	Quill Dia.	mm(in)	Ø80 (Ø3.1")	-	Ø80 (Ø3.1")	-	
	Quill Travel	mm(in)	120 (4.7")	-	120 (4.7")	-	
	Travel	mm(in)	680 (26.8")	-	680 (26.8")	-	
TANK CAPACITY	Coolant Tank	ℓ (gal)	200 (52.8)				
	Lubricating Tank	ℓ (gal)	2 (0.5)				
POWER SUPPLY	Electric Power Supply	kVA	27	32	27 [i-TROL : 32]	32 [i-TROL : 36]	
	Thickness of Power Cable	Sq	Over 25				
	Voltage	V/Hz	220/60 (200/50*)				
MACHINE	Floor Space (L×W)	mm(in)	3,380×1,800 (133.1"×70.9")				
	Height	mm(in)	1,950 (76.8")				
	Weight	kg(lb)	4,700 (10,362)	4,800 (10,803)	4,800 (10,582)	5,000 (11,023)	
CNC	Controller	-	HYUNDAI WIA FANUC i Series - Smart Plus [HYUNDAI-iTROL]				

*) Using 50Hz voltage instead of 60Hz may lower the output of motors. (excluding servo motors and inverter motors)
Specifications are subject to change without notice for improvement.

SPECIFICATIONS

Specifications

[] : Option

ITEM			HD3100YA	HD3100SYA	HD3100Y	HD3100SY
CAPACITY	Swing Over the Bed	mm(in)	Ø800 (Ø31.5")			
	Swing Over the Carriage	mm(in)	Ø670 (Ø26.4")			
	Max. Turning Dia.	mm(in)	Ø420 (Ø16.5")			
	Max. Turning Length	mm(in)	760 (Ø29.9")			
	Bar Capacity	Main	mm(in)	Ø81 (Ø3.2")		Ø102 (Ø4")
Sub		mm(in)	-	Ø51 (Ø2")	-	Ø51 (Ø2")
SPINDLE	Chuck Size	Main	10"		12"	
		Sub	-	6"	-	6"
	Spindle Bore	Main	Ø91 (Ø3.6")		Ø115 (Ø4.5")	
		Sub	-	Ø62 (Ø2.4")	-	Ø62 (Ø2.4")
	Spindle Speed (rpm)	Main	3,500		2,800	
		Sub	-	4,500	-	4,500
	Motor (Max/Cont.)	Main	26/18.5 (35/25)		26/18.5 (35/25)	
		Sub	-	7.5/5.5 (10/7.4)	-	7.5/5.5 (10/7.4)
	Torque (Max/Cont.)	Main	734/522		1,051/672	
		Sub	-	85/47	-	85/47
	Spindle Type	Main	BELT			
		Sub	-	BELT	-	BELT
	Spindle Nose	Main	A2-8		A2-11	
Sub		mm(in)	-	A2-5	-	A2-5
C-axis Indexing	deg	0.001°				
FEED	Travel	X/Y	265/120 {±60} (10.4"/4.7" {±2.4"})			
		Z/ZB	830 (32.7")	830/830 (32.7"/32.7")	830 (32.7")	830/830 (32.7"/32.7")
	Rapid Traverse Rate	X/Y	24/10 (944/394)			
		Z/ZB	30 (1,181)	30/30 (1,181/1,181)	30 (1,181)	30/30 (1,181/1,181)
Slide Type	-	BOX GUIDE				
TURRET	Po. of Tools	ea	12			
	Tool Size	O.D/I.D	□ 25 (□ 1") / Ø50 (Ø2")			
	Indexing Time	sec/step	0.2			
	Y-Axis Type	-	WEDGE TYPE			
LIVE TOOL	Milling Tool Speed (rpm)	r/min	5,000			
	Motor (Max/Cont.)	kW(HP)	5.5/3.7 (7.4/5)			
	Torque (Max/Cont.)	N·m	70/35.4			
	Collet Size	mm(in)	Ø25 (Ø1") {ER32}			
	Type	-	BMT65P			
TAIL STOCK	Taper	-	MT#5	-	MT#5	-
	Quill Dia.	mm(in)	Ø100 (Ø3.9")	-	Ø100 (Ø3.9")	-
	Quill Travel	mm(in)	120 (4.7")	-	120 (4.7")	-
	Travel	mm(in)	830 (32.7")	-	830 (32.7")	-
TANK CAPACITY	Coolant Tank	ℓ (gal)	200 (52.8)			
	Lubricating Tank	ℓ (gal)	1.8			
POWER SUPPLY	Electric Power Supply	kVA	33		27	
	Thickness of Power Cable	Sq	Over 25			
	Voltage	V/Hz	220/60 (200/50*)			
MACHINE	Floor Space (L×W)	mm(in)	3,630×1,910 (142.9"×75.2")			
	Height	mm(in)	1,960 (77.2")			
	Weight	kg(lb)	6,200 (13,669)		6,300 (13,889)	
CNC	Controller	-	HYUNDAI WIA FANUC i Series - Smart Plus			

*) Using 50Hz voltage instead of 60Hz may lower the output of motors. (excluding servo motors and inverter motors)

Specifications are subject to change without notice for improvement.

CONTROLLER

HYUNDAI WIA FANUC i Series – Smart Plus

[] : Option

Controlled axis / Display / Accuracy Compensation	
Control axes	2 axes (X, Z) / 3 axes (X, Z, C) / 4 axes (X,Z,Y,C) 5 axes (X, Z, B, C, A) / 6 axes (X, Z, Y, B, C, A) 7 axes (X1/Z1, X2/Z2, B2, C1/C2)
Simultaneously controlled axes	2 axes [Max. 4 axes]
Designation of spindle axes	3 axes [Max. 4 axes]
Least setting Unit	X, Z, Y, B axes : 0.001 mm (0.0001 inch) C, A axes : 0.001 deg
Least input increment	X, Z, Y, B axes : 0.001 mm (0.0001 inch) C, A axes : 0.001 deg
Inch / Metric conversion	G20 / G21
High response vector control	
Interlock	All axes / Each axis
Machine lock	All axes
Backlash compensation	± 0~9999 pulses (exc. Rapid traverse / Cutting feed)
Position switch	
LCD / MDI	15 inch LCD unit (with Touch Panel)
Feedback	Absolute motor feedback
Stored stroke check 1	Over travel
Stored stroke check 2, 3	
PMC axis control	
Operation	
Automatic operation (Memory)	
MDI operation	
DNC operation	Needed DNC software / CF card
Program restart	
Wrong operation prevention	
Program check function	Dry run
Single block	
Search function	Program Number / Sequence Number
Interpolation functions	
Nano interpolation	
Positioning	G00
Linear interpolation	G01
Circular interpolation	G02, G03
Exact stop mode	Single : G09, Continuous : G61
Dwell	G04, 0 ~ 9999.9999 sec
Skip	G31
Reference position return	1st reference : G28, 2nd reference : G30 Ref. position check : G27
Thread synchronous cutting	G33
Thread cutting retract	
Variable lead thread cutting	
Multi / Continuous threading	
Feed function / Acc. & Dec. control	
Manual feed	Rapid traverse Jog : 0~2,000 mm/min (79 ipm) Manual handle : x1, x10, x100 pulses Reference position return
Cutting Feed command	Direct input F code
Feedrate override	0 ~ 200% (10% Unit)
Rapid traverse override	1%, F25%, 50%, 100%
Override cancel	
Feed per minute	G98
Feed per revolution	G99
Look-ahead block	1 block
Program input	
Tape Code	EIA / ISO
Optional block skip	1 ea
Absolute / Incremental program	G90 / G91
Program stop / end	M00, M01 / M02, M30
Maximum command unit	± 999,999.999 mm (± 99,999.9999 inch)
Plane selection	X-Y : G17 / Z-X : G18 / Y-Z : G19
Workpiece coordinate system	G52, G53, 6 pairs (G54 ~ G59)
Manual absolute	Fixed ON
Programmable data input	G10
Sub program call	10 folds nested
Custom macro	#100 ~ #199, #500 ~ #999
G code system	A, B/C
Programmable mirror image	G51.1, G50.1
G code preventing buffering	G4.1
Direct drawing dimension program	Including Chamfering / Corner R
Conversational Program	SmartGuide-i

Program input	
Multiple repetitive cycles	I, II
Canned cycle for turning	
Auxiliary function / Spindle speed function	
Auxiliary function	M & 4 digit
Level-up M Code	High speed / Multi / Bypass M code
Spindle speed function	S & 5 digit, Binary output
Spindle override	0% ~ 150% (10% Unit)
Multi position spindle orientation	M19 (S##)
FSSB Rigid tapping	
Constant surface speed control	G96, G97
Tool function / Tool compensation	
Tool function	T & 2 digit + Offset 2 digit
Tool life management	
Tool offset pairs	128 pairs
Tool nose radius compensation	G40, G41, G42
Geometry / Wear compensation	
Direct input of offset measured B	
Editing function	
Part program storage size	5,120m (2MB)
No. of registerable programs	1,000 ea
Program protect	
Background editing	
Extended part program editing	Copy, move and change of NC program
Memory card program edit	
Data input / output & Interface	
I/O interface	CF card, USB memory Embedded Ethernet interface
Screen hard copy	
External message	
External key input	
External workpiece number search	
Automatic data backup	
Setting, display and diagnosis	
Self-diagnosis function	
History display & Operation	Alarm & Operator message & Operation
Run hour / Parts count display	
Maintenance information	
Actual cutting feedrate display	
Display of spindle speed / T code	
Graphic display	
Operating monitor screen	Spindle / Servo load etc.
Power consumption monitoring	Spindle & Servo
Spindle / Servo setting screen	
Multi language display	Support 24 languages
Display language switching	Selection of 5 optional Languages
LCD Screen Saver	Screen saver
Unexpected disturbance torque	BST (Back spin torque limit)
Function for machine type	
Cs contour control (C & A axes)	Mill, MS, Y, SY, LF-Mill, TTMS, TTSY
Polar coordinate interpolation	Mill, MS, Y, SY, LF-Mill, TTMS, TTSY
Cylindrical interpolation	Mill, MS, Y, SY, LF-Mill, TTMS, TTSY
Polygon turning (2 Spindles)	Mill, MS, Y, SY, LF-Mill, TTMS, TTSY
Canned cycle for drilling	Mill, MS, Y, SY, LF-Mill, TTMS, TTSY
Spindle orientation expansion	MS, SY, TTS, TTMS, TTSY
Spindle synchronous control	MS, SY, TTS, TTMS, TTSY
Torque control	MS, SY, TTS, TTMS, TTSY
Y axis offset	Y, SY, TTSY
Arbitrary angular control	Y, SY, TTSY
Composite / Superimposed control	MS, SY, TTS, TTMS, TTSY
Balance cutting	TTS, TTMS, TTSY
Option	
Additional optional block skip	9 ea
Fast ethernet	Needed option board
Data server	Needed option board
Protection of data at 8 levels	
Tool offset pairs	200 pairs
Helical interpolation	
Optional block skip	40 ea, 200 ea (AICC II)

Figures in inch are converted from metric values.

The FANUC controller specifications are subject to change based on the policy of company CNC supplying.

CONTROLLER

HYUNDAI-iTROL (HD2200Y/SY | HD2600Y/SY)

Control & Composition	
Number of axis/Spindles	2 axes (X, Z) / 3 axes (X, Z, C)
Number of axis/Spindles, max.	8 axes (Axis + Spindle)
Color display	TFT 10.4" Color (800 x 600)
Keyboard	QWERTY Full Keyboard
Part program storage	1MB, 3MB, 5MB
Addition of part program on CF card	
Transfer Function	
Feedrate override	0% ~ 200%
Transfer value input range	± 999999999
Unlimited rotation of rotation axis	
Acc./Dec. with jerk limitation	
Measuring systems 1 and 2, selectable	
Travel to fixed stop	
Auto servo drive tuning	
Spindle Function	
Spindle override	0% ~ 150%
Spindle speed, max. programmable value range	1000000 ~ 0.0001
Automatic gear stage selection	
Spindle orientation	
Spindle speed limitation	
Rigid tapping	
Spindle control with PLC	
Interpolation	
Linear interpolation axis, max.	4 axis
Circle via center point and end point	
Circle via interpolation point	
Helical interpolation	
Non-uniform rational B splines	
Continuous - path mode with programmable rounding clearance	
Program Function	
Subroutine levels, max.	7
Interrupt routines, max.	2
Number of levels for skip blocks	2
Polar Coordinates	
Dimensions inch/metric, changeover manually or via program	
Dynamic preprocessing memory FIFO	
Look ahead	1
Absolute/Incremental command	G90 / G91
Scaling/Rotation	
Read/Write system variables	
Block search	
Edit background	
Processing program number, max.	750
Using of CF Card, USB	
Basic coordinate number, max.	1
Work coordinate number, max.	100
Basic/Work coordinate programming change	
Scratching function	
Global and Local user data (GUD/LUD)	
Global program user data	
Conversational Cycle Program	
Tool Function	
Tool radius compensations	
Tool offset selection via T/D numbers	
Tools / Cutting edges in tool list	128 / 256, 256 / 512
Monitoring Function	
Working area limit	
Software and Hardware limit	
Zero-speed/Clamping monitoring	
2D/3D protection zones	
Contour monitoring	

Compensation	
Backlash compensation	
Leadscrew error compensation	
Measuring system error compensation	
Feedforward control (Speed control)	
Safety Function	
Safe torque off (STO)	
Safe brake control (SBC)	
Safe stop 1 (SS1)	
Diagnostic Function	
Alarm/Message . Alarm log	
PLC status/LAD online display	
PLC remote connection (Ethernet)	
Automation Support Function	
Actual velocity display	
Tool life management	As time / As amount
Work counter/Cycle time	Embedded
2D simulation	
Manual Operation	
Manual handle/Log transfer	
Manual measurement of workpiece / tool offset	
Automatic tool/Workpiece measurement	
Automatic/Program reference approach	
Automatic Operation	
Program run as using CF card/USB	
Program control/modification	
Block search	
Reposition	
Preset (Set actual value)	
Data Transmission	
Ethernet network	
USB memory stick & CF card	
Convenience Function	
Processing setting	Coordinate system setting, Auto tool length measurement
Processing support	Tool Monitoring, Spindle overload monitoring
Maintenance	Turret Guidance, I/O monitoring, Manual
Management	Soft MCP, M/G code List
SMART machining	
Energy saving function (ECO)	
Machine Monitoring System (MMS Lite)	
Language	
Standard support language	Chinese Simplified, English, Korean
Option	
Maximum skip block number	10
DRF offset	
MDI program save/load	
Teach-In mode	
3D simulation	Except for working area/Collision check
Real time simulation	
Shop Turn	Conversational Program
Spline interpolation	
Program remote control in network	
Language	Chinese Traditional, French, German, Italian, Portuguese, Spanish

HW-MMS

HYUNDAI WIA Machine Monitoring System



A brand new manufacturing machine by Hyundai Wia, HW-MMS is a unique software capable of monitoring the operation status of manufacturing machines in factories, a smart solution to improve manufacturing conditions of customers.

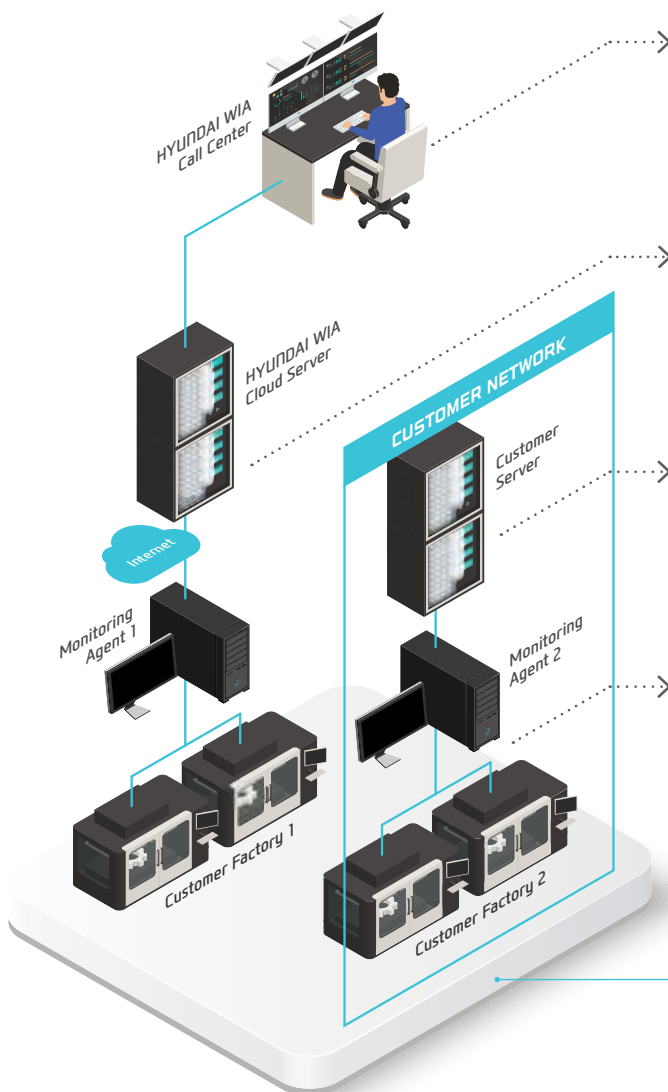

HW-MMS Remote

Hyundai Wia Call Center's remote diagnosis service provides a HMI/video diagnostic function.



HW-MMS Cloud

A cloud server-based equipment monitoring system for collecting and analyzing facility operation data.



HW-MMS Edge

A client server-based tool monitoring system for collection/analysis of facility operation data. (Compatible with client MES / ERP interface)



HW-MMS PT

This is a facility big data-based smart factory solution that collects and analyzes changes in spindle/feed data and NC processing files

HYUNDAI WIA
Smart Factory Solution



You Tube HYUNDAI WIA MT

www.youtube.com/HYUNDAIWIAMT

EXPERIENCE THE NEW TECHNOLOGY

With its top-quality HYUNDAI WIA machine tool creates a new and better world.



<http://machine.hyundai-wia.com>

HYUNDAI WIA Machine Tools
Global Links

HEADQUARTER

Changwon Technical Center/R&D Center/Factory 153, Jeongdong-ro, Seongsan-gu, Changwon-si, Gyeongsangnam-do, Korea TEL : +82 55 280 9114 FAX : +82 55 282 9114

Overseas Sales Team /R&D Center 37, Cheoldobangmulgwan-ro, Uiwang-si, Gyeonggi-do, Korea TEL : +82 31 8090 2539

OVERSEAS OFFICES

HYUNDAI WIA Machine America corp. 450 Commerce Blvd, Carlstadt, NJ 07072, USA TEL : +1-201-987-7298

HYUNDAI WIA Europe GmbH Alexander-Fleming-Ring 57, 65428 Rüsselsheim Germany TEL : +49-0-6142-9256-0

HYUNDAI WIA Machine Tools China 2-3F, Bldg6, No.1535 Hongmei Road, Xuhui District, Shanghai, China TEL : +86-21-6427-9885

India Branch Office #4/169, 1st Floor, LOTTE BLDG, Rajiv Gandhi Salai, (OMR), Kandanchavadi, Chennai - 600096, Tamilnadu, India TEL : +91-76-0490-3348

Vietnam Branch Office Flat number 05, Service and Trade Center of Viet Huong Industrial Zone, Highway 13, Thuan Giao, Thuan An, Binh Duong, Vietnam TEL : +84-3-5399-5099