

C:\Ibarmia\PROYECTOS\1.MAQ.02\12\1STAR07\4_DISEÑO\5_DOCUMENTOS\VALIDACION\PLAY-ZVH45-L3000-21STAR07.dft

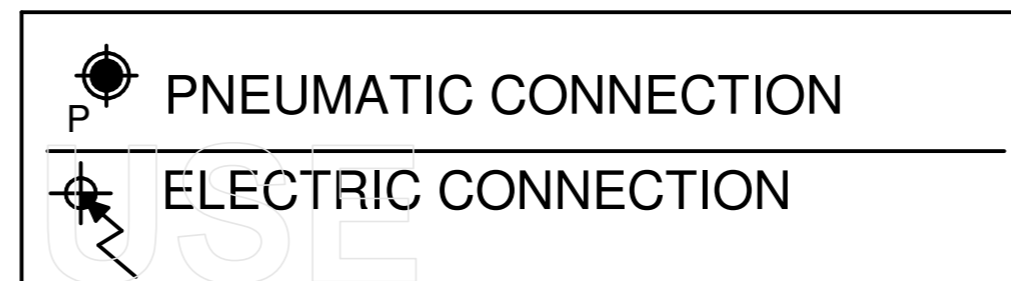

INDEX	LETTER	MODIFICATION	DATE	NAME
-	-	-	-	-
-	-	-	-	-
-	-	-	-	-
PIECES	DENOMINATION		MATERIAL	
	Plano de LAYOUT ZVH45-L3000 21STAR07			
~ = √	∇ = 12/0.2	NOT SPECIFIED TOLERANCES	SCALE	DRAWN
∇∇ = 32/12	∇∇∇ = 0.2/0.2	ISO - 2768 - m	ISO 1101	DATE
			ORIGINAL DIN A2 (CAD)	NAME
MACHINE SERIE	ZVH45/L3000 STAR	MAQ Nº 21STAR07	BENDER	REPLACES
				REPLACED BY
				ARTICLE CODE
				21STAR03
				DRAWING NUMBER
				PLAY-ZVH45-L3000 21STAR07-01

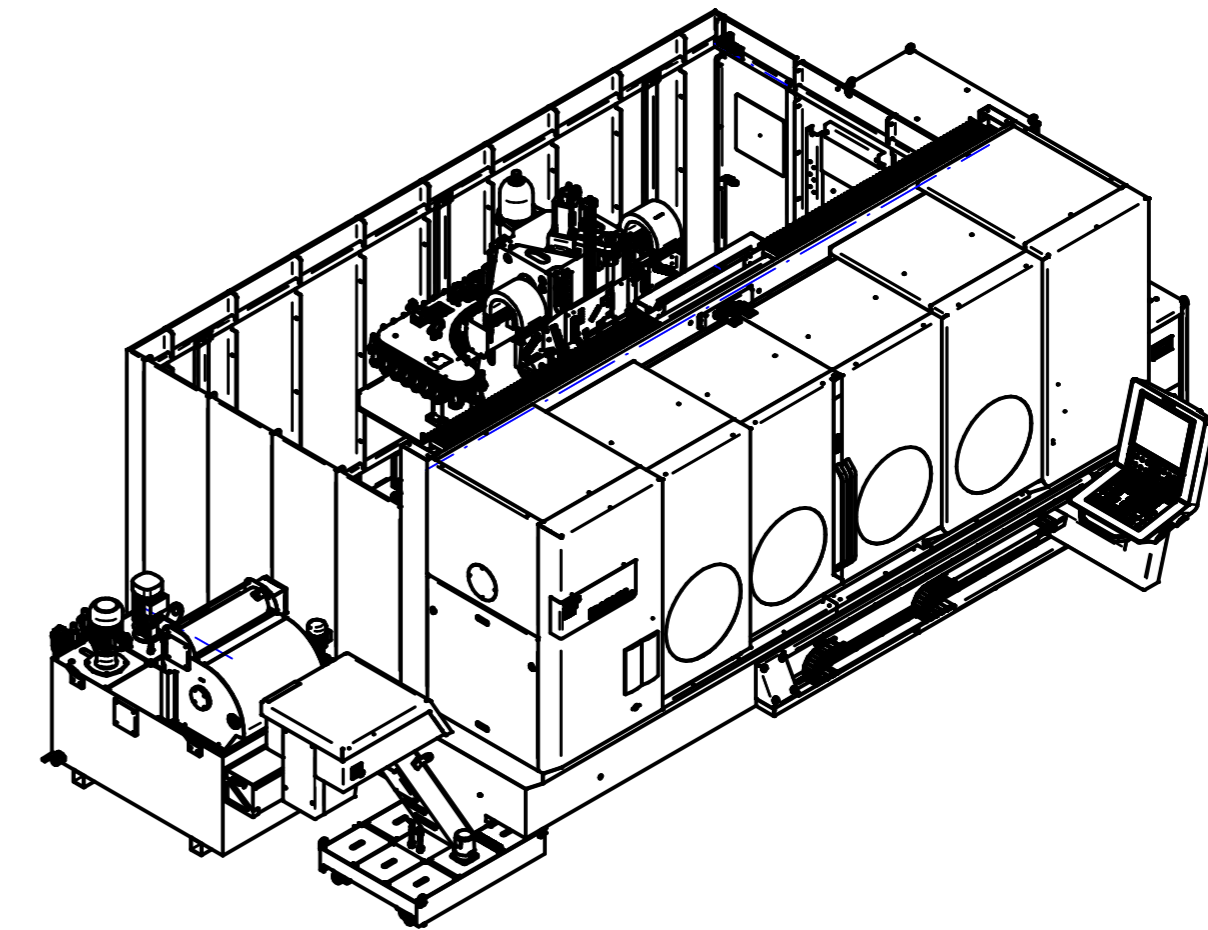
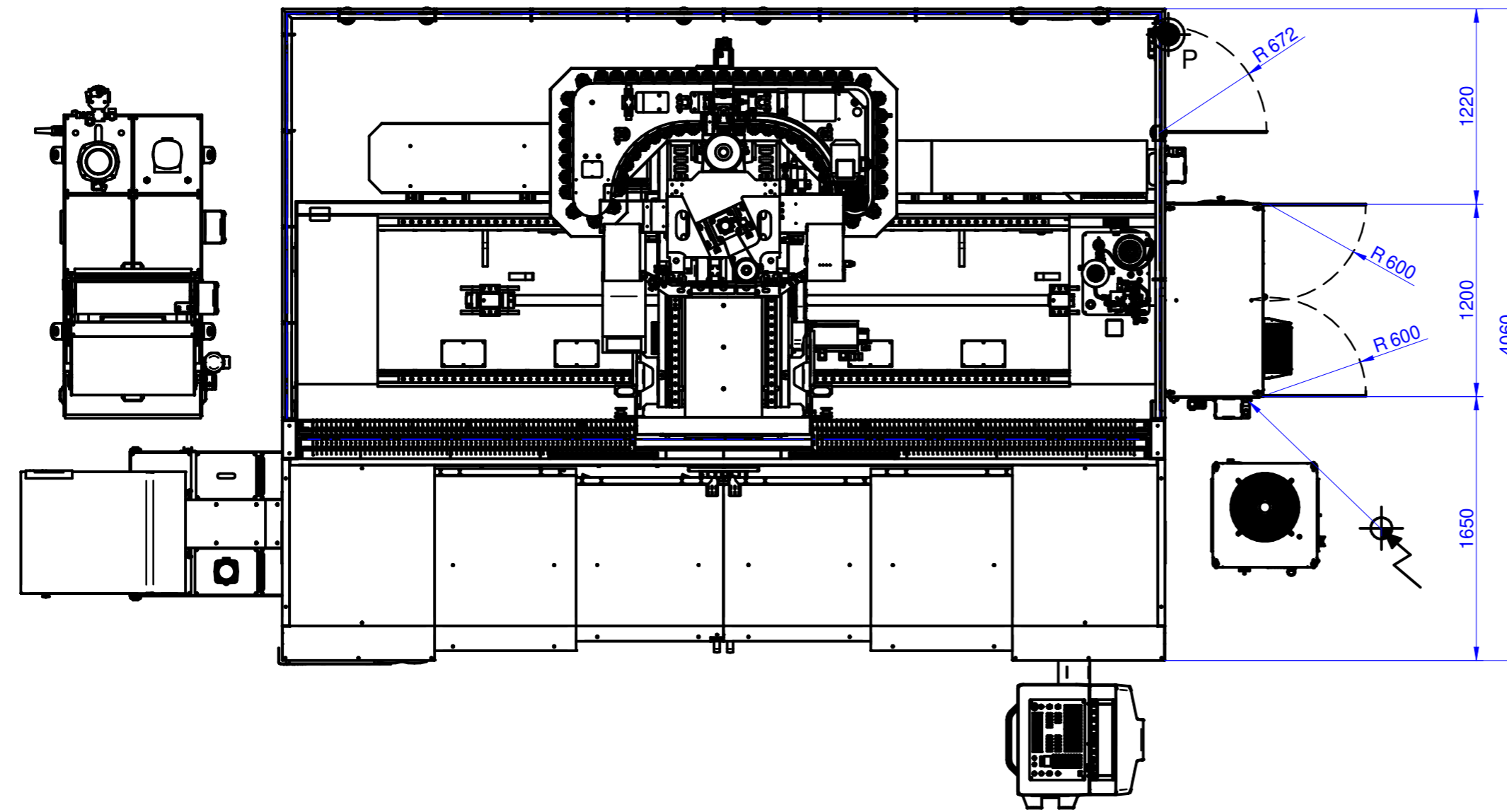
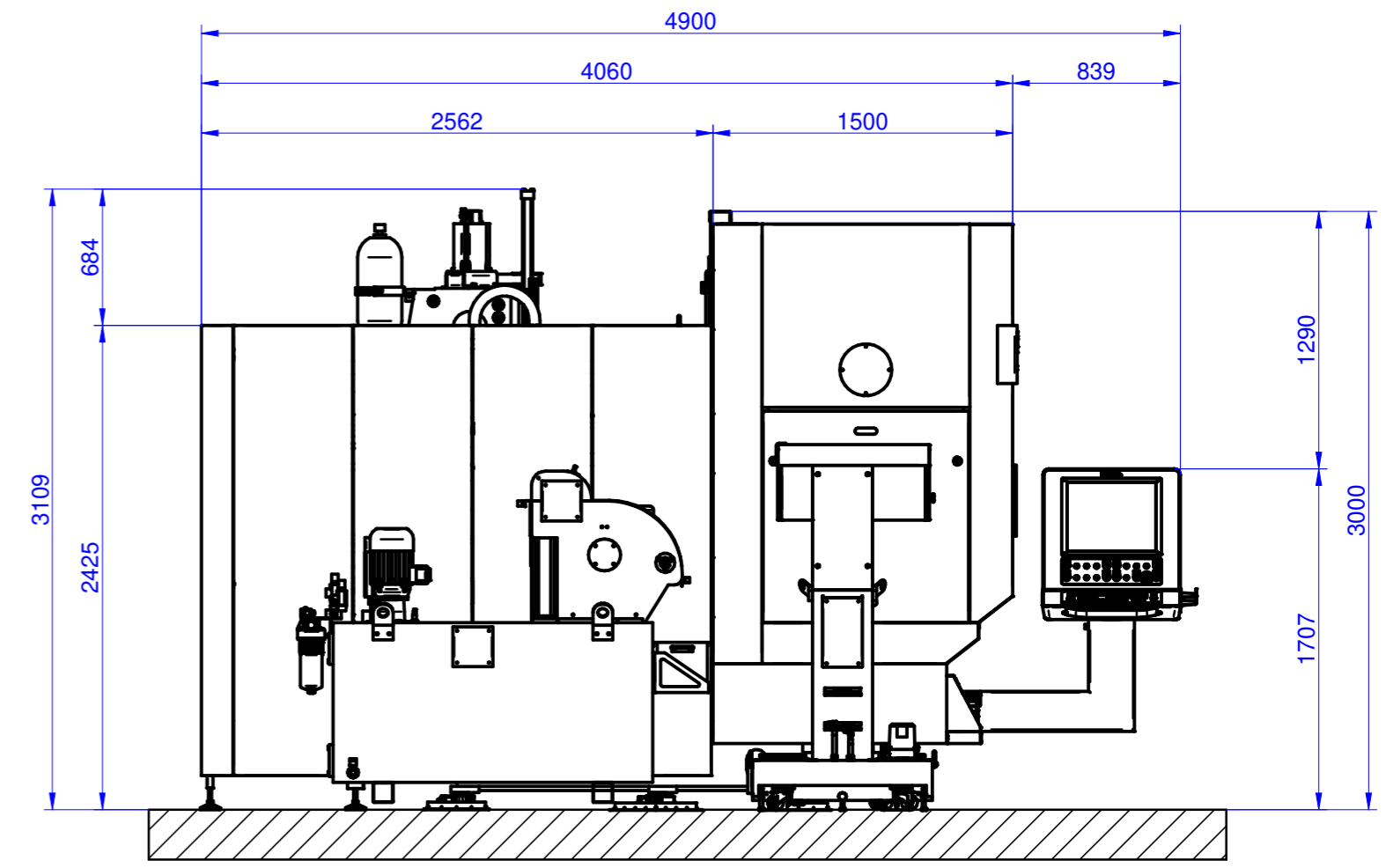
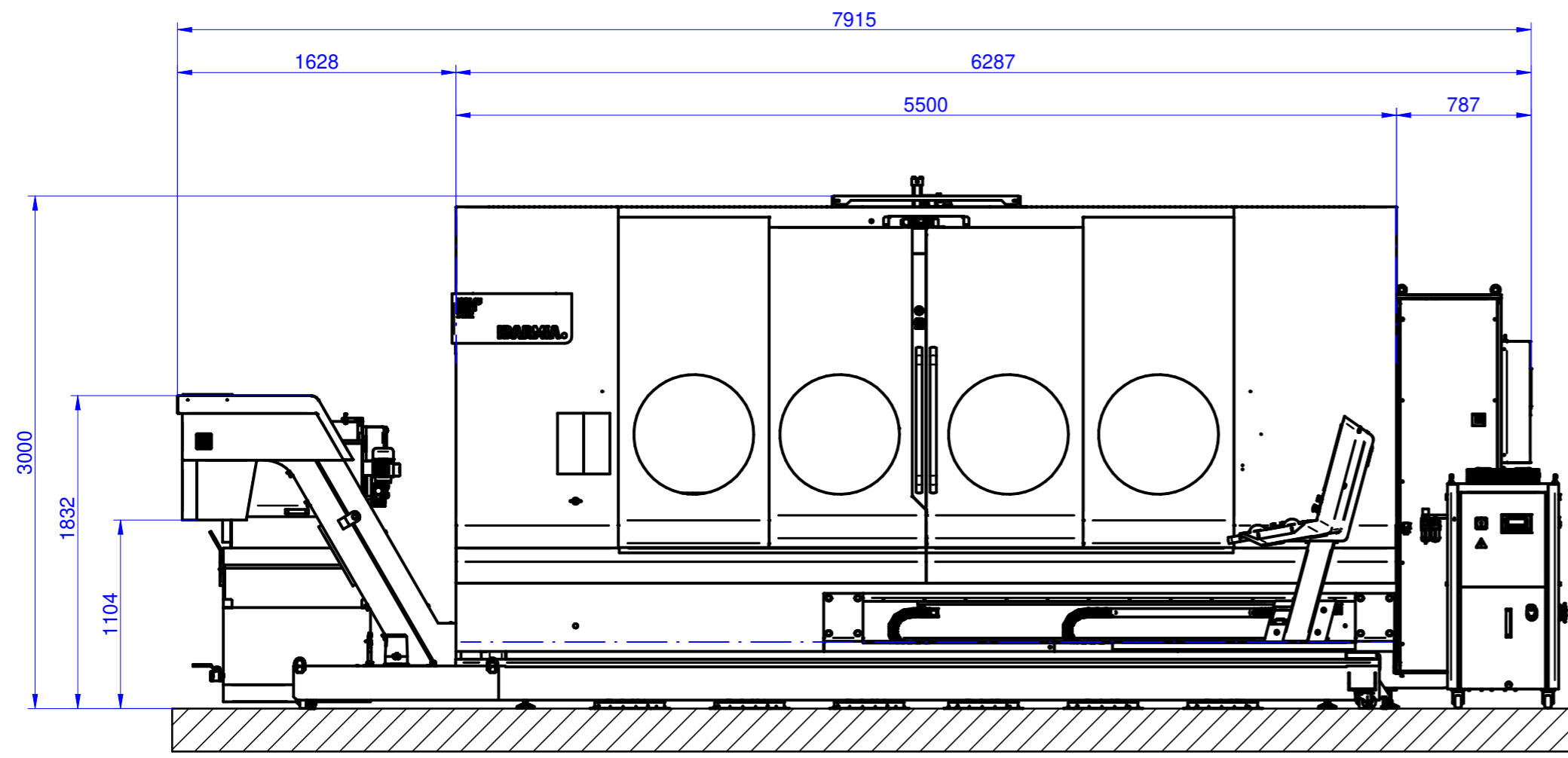